



## MT9P011: 5-Megapixel CMOS Digital Image Sensor Die Features

# 1/2.5-Inch, 5-Megapixel CMOS Digital Image Sensor Die

## MT9P011

For the product data sheet, refer to Micron's Web site: [www.micron.com](http://www.micron.com)

### Features

- Micron® DigitalClarity® image sensor technology
- High frame rate
- Superior low-light performance
- Low dark current
- Global reset release, which starts exposure of all rows simultaneously
- Bulb exposure mode, for arbitrary exposure times
- Snapshot mode to take frames on demand
- Horizontal and vertical mirror image
- Column and row skip modes reduce image size without reducing the field-of-view
- Column and row binning modes to improve image quality when resizing
- Simple two-wire serial interface
- Programmable controls: gain, frame rate, frame size, exposure
- On-die PLL

### General Physical Specifications

- Die thickness:  $200\mu\text{m} \pm 12\mu\text{m}$   
(Consult factory for other thicknesses)
- Backside wafer surface of bare silicon
- Typical metal 1 thickness:  $3.1\text{k}\text{\AA}$
- Typical metal 2 thickness:  $3.1\text{k}\text{\AA}$
- Typical metal 3 thickness:  $6.1\text{k}\text{\AA}$
- Metallization composition: 99.5 percent Al and 0.5 percent Cu over Ti
- Typical topside passivation:  
 $2.2\text{k}\text{\AA}$  nitride over  $6.0\text{k}\text{\AA}$  of undoped oxide
- Passivation openings (MIN):  $75\mu\text{m} \times 90\mu\text{m}$

### Order Information

MT9P011D00STCC18BC1

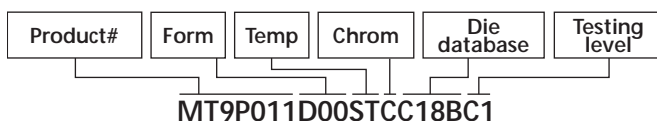

### Die Database C18B

- Die outline, see Figure 2 on page 9
- Singulated die size:  $8,499 \pm 25\mu\text{m} \times 7,950 \pm 25\mu\text{m}$
- Bond Pad Identification Tables, see pages 5–8

### Options

- Form
  - Die
- Testing
  - Standard (level 1) probe

### Designator

D

C1

Notes: 1. Please consult die distributor or factory before ordering to verify long-term availability of these die products.

### Key Performance Parameters

- Optical format: 1/2.5-inch (4:3)
- Active imager size: 5.70mm(H) x 4.28mm(V), 7.13mm diagonal
- Active pixels: 2,592H x 1,944V
- Pixel size:  $2.2\mu\text{m} \times 2.2\mu\text{m}$
- Color filter array: RGB Bayer pattern
- Shutter type
  - Global reset release (GRR), snapshot only
  - Electronic rolling shutter (ERS)
- Maximum data rate/master clock
  - 96 Mp/s at 96 MHz (2.8V I/O)
  - 48 Mp/s at 48 MHz (1.8V I/O)
- Frame rate
  - Full resolution, programmable up to 14 fps
  - VGA (640H x 480V, with binning), programmable up to 53 fps
- ADC resolution: 12-bit, on-die
- Responsivity: 1.4 V/lux-sec (550nm)
- Pixel dynamic range: 70.1dB
- $\text{SNR}_{\text{MAX}}$ : 38.1dB
- Supply voltage: I/O Digital: 1.7–3.1V
  - Digital: 1.7–1.9V (1.8V nominal)
  - Analog: 2.6–3.1V (2.8V nominal)
- Power consumption: 381mW (full resolution)
- Operating temperature:  $-30^{\circ}\text{C}$  to  $+70^{\circ}\text{C}$



## MT9P011: 5-Megapixel CMOS Digital Image Sensor Die General Description

### General Description

The Micron Imaging MT9P011 is a 1/2.5-inch CMOS active-pixel digital image sensor die with an active imaging pixel array of 2,592H x 1,944V. It incorporates sophisticated camera functions on-die such as windowing, column and row skip mode, and snapshot mode. It is programmable through a simple two-wire serial interface.

The 5-megapixel CMOS image sensor die features DigitalClarity—Micron's breakthrough low-noise CMOS imaging technology that achieves CCD image quality (based on signal-to-noise ratio and low-light sensitivity) while maintaining the inherent size, cost, and integration advantages of CMOS.

The sensor can be operated in its default mode or programmed by the user for frame size, exposure, gain setting, and other parameters. The default mode outputs a full resolution image at 14 frames per second (fps).

An on-die analog-to-digital converter (ADC) provides 12 bits per pixel. FRAME\_VALID and LINE\_VALID signals are output on dedicated pins, along with a pixel clock that is synchronous with valid data.

The MT9P011 produces extraordinarily clear, sharp digital pictures, and its ability to capture both continuous video and single frames makes it the perfect choice for a wide range of consumer and industrial applications, including digital still cameras, digital video cameras, and PC cameras.

### Die Testing Procedures

Micron imager die products are tested with a standard probe (C1) test level. Wafer probe is performed at an elevated temperature to ensure product functionality in Micron's standard package. Since the package environment is not within Micron's control, the user must determine the necessary heat sink requirements to ensure that the die junction temperature remains within specified limits.

Image quality is verified through various imaging tests. The probe functional test flow provides test coverage for the on-die ADC, logic, serial interface bus, and pixel array. Test conditions, margins, limits, and test sequence are determined by individual product yields and reliability data.

Micron retains a wafer map of each wafer as part of the probe records, along with a lot summary of wafer yields for each lot probed. Micron reserves the right to change the probe program at any time to improve the reliability, packaged device yield, or performance of the product.

Die users may experience differences in performance relative to Micron's data sheets. This is due to differences in package capacitance, inductance, resistance, and trace length.

### Functional Specifications

These specifications are provided for reference only. For functional and parametric specifications, refer to the product data sheet found on Micron's Web site.

### Bonding Instructions

The MT9P011 imager die has 67 bond pads. Refer to Table 1 and Table 2, on pages 5–8, for a complete list of bond pads and coordinates.



## MT9P011: 5-Megapixel CMOS Digital Image Sensor Die Storage Requirements

The MT9P011 imager die does not require the user to determine bond option features.

The die also has several pads defined as “do not use.” These pads are used for engineering purposes and should not be used. Bonding these pads could result in a nonfunctional die.

Figure 1 on page 4 shows the typical die connections. For low-noise operation, the MT9P011 die requires separate supplies for analog and digital power. Power supply rails should be decoupled to ground using capacitors. The use of inductance filters is not recommended.

All DGND pads must be tied together, as must all AGND pads, all VDDQ pads, and all VDD pads. Doing so will minimize risk of damage to the sensor in an ESD event.

### Storage Requirements

Micron die products are packaged in a cleanroom environment for shipping. Upon receipt, the customer should transfer the die or wafers to a similar environment for storage. Micron recommends the die or wafers be maintained in a filtered nitrogen atmosphere until removed for assembly. The moisture content of the storage facility should be maintained at 30 percent relative humidity  $\pm$ 10 percent. ESD damage precautions are necessary during handling. The die must be in an ESD-protected environment at all times for inspection and assembly.

### Product Reliability Monitors

Reliability of all packaged products is monitored by ongoing reliability evaluations. Micron's QRA department continually samples product families for reliability studies. These samples are subjected to a battery of tests known as the “Accelerated Life” and “Environmental Stress” tests. During these tests, devices are stressed for many hours under conditions designed to simulate years of normal field use. A summary of these product family evaluations is published on a regular basis.



# MT9P011: 5-Megapixel CMOS Digital Image Sensor Die Typical Configuration

## Typical Configuration

Figure 1 shows typical configuration schematics for the MT9P011.

Figure 1: Typical Configuration (Connection) Parallel Mode

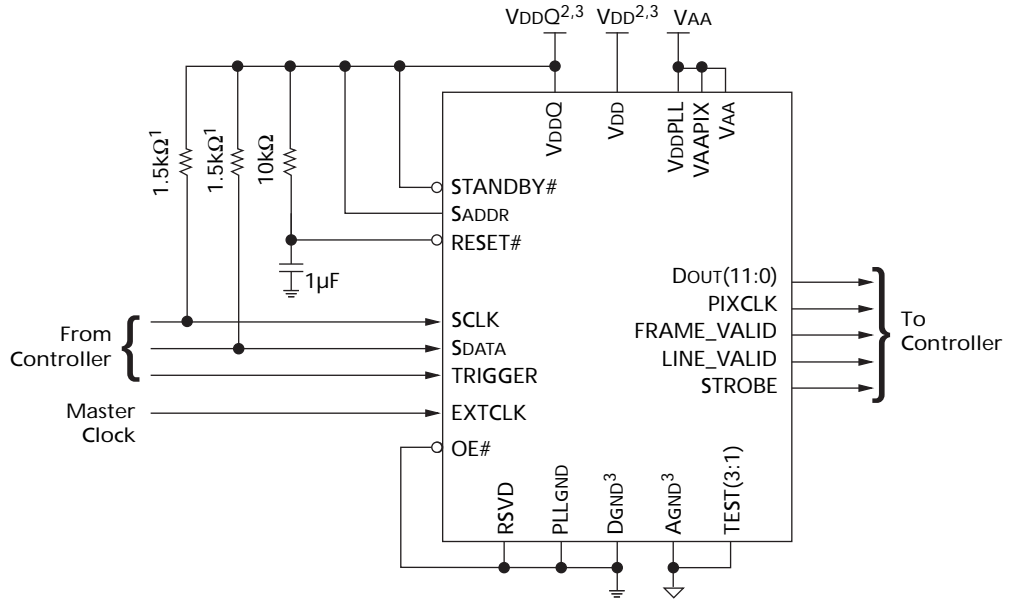

- Notes:
1. A Resistor value of 1.5kΩ is recommended, but may be greater for slower two-wire speed.
  2. All power supplies should be adequately decoupled.
  3. All DGND pads must be tied together, as must all AGND pads, all VDDQ pads, and all VDD pads.



## MT9P011: 5-Megapixel CMOS Digital Image Sensor Die Bond Pad Identification Tables

### Bond Pad Identification Tables

Table 1: Bond Pad Location and Identification from Center of Pad 1

Pad	MT9P011	"X" <sup>1</sup> Microns	"Y" <sup>1</sup> Microns	"X" <sup>1</sup> Inches	"Y" <sup>1</sup> Inches
1	DNU <sup>2</sup>	0.00	0.00	0.0000000	0.0000000
2	DNU	131.04	0.00	0.0051591	0.0000000
3	DNU	7592.00	0.00	0.2988976	0.0000000
4	DNU	7723.04	0.00	0.3040567	0.0000000
5	VDD1	7970.63	-258.39	0.3138041	-0.0101726
6	VDD2	7970.63	-400.23	0.3138041	-0.0157569
7	DGND3	7970.63	-749.43	0.3138041	-0.0295049
8	DGND4	7970.63	-880.47	0.3138041	-0.0346640
9	DOUT11	7970.63	-1115.47	0.3138041	-0.0439159
10	DOUT10	7970.63	-1350.47	0.3138041	-0.0531679
11	DOUT9	7970.63	-1605.03	0.3138041	-0.0631900
12	DOUT8	7970.63	-1840.03	0.3138041	-0.0724419
13	DOUT7	7970.63	-2094.59	0.3138041	-0.0824640
14	DOUT6	7970.63	-2329.59	0.3138041	-0.0917159
15	DGND5	7970.63	-2564.59	0.3138041	-0.1009679
16	DGND6	7970.63	-2695.63	0.3138041	-0.1061270
17	VDDQ3	7970.63	-2930.63	0.3138041	-0.1153789
18	VDDQ4	7970.63	-3072.47	0.3138041	-0.1209632
19	DOUT5	7970.63	-3307.47	0.3138041	-0.1302152
20	DOUT4	7970.63	-3562.03	0.3138041	-0.1402372
21	DOUT3	7970.63	-3797.03	0.3138041	-0.1494892
22	DOUT2	7970.63	-4051.59	0.3138041	-0.1595112
23	DOUT1	7970.63	-4286.59	0.3138041	-0.1687632
24	DOUT0	7970.63	-4541.15	0.3138041	-0.1787852
25	PIXCLK	7970.63	-4776.15	0.3138041	-0.1880372
26	EXTCLK	7970.63	-5030.71	0.3138041	-0.1980593
27	DNU	7970.63	-5421.19	0.3138041	-0.2134325
28	DNU	7970.63	-5711.19	0.3138041	-0.2248498
29	DNU	7970.63	-6077.83	0.3138041	-0.2392844
30	DNU	7970.63	-6367.83	0.3138041	-0.2507018
31	PLL <sub>GND</sub>	7970.63	-6899.27	0.3138041	-0.2716246
32	VDD <sub>PLL</sub>	7970.63	-7134.27	0.3138041	-0.2808766
33	DNU	131.04	-7669.53	0.0051591	-0.3019500
34	DNU	0.00	-7669.53	0.0000000	-0.3019500
35	VAA4	-247.59	-7411.15	-0.0097474	-0.2917774
36	VAA3	-247.59	-7269.31	-0.0097474	-0.2861931
37	VAA2	-247.59	-7127.47	-0.0097474	-0.2806089
38	VAA1	-247.59	-6985.63	-0.0097474	-0.2750246
39	AGND6	-247.59	-6750.63	-0.0097474	-0.2657726
40	AGND5	-247.59	-6619.59	-0.0097474	-0.2606136



## MT9P011: 5-Megapixel CMOS Digital Image Sensor Die Bond Pad Identification Tables

**Table 1: Bond Pad Location and Identification from Center of Pad 1 (continued)**

Pad	MT9P011	"X" <sup>1</sup> Microns	"Y" <sup>1</sup> Microns	"X" <sup>1</sup> Inches	"Y" <sup>1</sup> Inches
41	AGND4	-247.59	-6488.55	-0.0097474	-0.2554545
42	AGND3	-247.59	-6357.51	-0.0097474	-0.2502955
43	TEST1 <sup>3</sup>	-247.59	-6122.51	-0.0097474	-0.2410435
44	TEST2 <sup>3</sup>	-247.59	-5887.51	-0.0097474	-0.2317915
45	DNU	-247.59	-5652.51	-0.0097474	-0.2225396
46	DNU	-247.59	-5417.51	-0.0097474	-0.2132876
47	OE#	-247.59	-4911.51	-0.0097474	-0.1933663
48	RESET#	-247.59	-4676.51	-0.0097474	-0.1841144
49	TRIGGER	-247.59	-4441.51	-0.0097474	-0.1748624
50	STANDBY#	-247.59	-4206.51	-0.0097474	-0.1656104
51	SADDR	-247.59	-3971.51	-0.0097474	-0.1563585
52	VDD3	-247.59	-3799.59	-0.0097474	-0.1495900
53	VDDQ2	-247.59	-3344.55	-0.0097474	-0.1316750
54	VDDQ1	-247.59	-3202.71	-0.0097474	-0.1260907
55	DGND2	-247.59	-3071.67	-0.0097474	-0.1209317
56	DGND1	-247.59	-2940.63	-0.0097474	-0.1157726
57	STROBE	-247.59	-2747.83	-0.0097474	-0.1081821
58	LINE_VALID	-247.59	-2512.83	-0.0097474	-0.0989301
59	FRAME_VALID	-247.59	-2258.27	-0.0097474	-0.0889081
60	RSVD <sup>4</sup>	-247.59	-2023.27	-0.0097474	-0.0796561
61	SDATA	-247.59	-1788.27	-0.0097474	-0.0704041
62	SCLK	-247.59	-1553.27	-0.0097474	-0.0611522
63	TEST3 <sup>3</sup>	-247.59	-1068.55	-0.0097474	-0.0420687
64	AGND2	-247.59	-833.55	-0.0097474	-0.0328167
65	AGND1	-247.59	-702.51	-0.0097474	-0.0276577
66	VAAPIX2	-247.59	-467.51	-0.0097474	-0.0184057
67	VAAPIX1	-247.59	-325.67	-0.0097474	-0.0128215

- Notes:
1. Reference to center of each bond pad from center of bond pad number 1.
  2. DNU = "do not use." See "Bonding Instructions" on page 2.
  3. TEST1-TEST3 pads must be tied to AGND for normal device operation.
  4. RSVD pad must be tied to DGND for normal device operation.



## MT9P011: 5-Megapixel CMOS Digital Image Sensor Die Bond Pad Identification Tables

**Table 2: Bond Pad Location and Identification from Center of Die**

Pad	MT9P011	"X" <sup>1</sup> Microns	"Y" <sup>1</sup> Microns	"X" <sup>1</sup> Inches	"Y" <sup>1</sup> Inches
1	DNU <sup>2</sup>	-3861.52	3834.77	-0.1520283	0.1509750
2	DNU	-3730.48	3834.77	-0.1468693	0.1509750
3	DNU	3730.48	3834.77	0.1468693	0.1509750
4	DNU	3861.52	3834.77	0.1520283	0.1509750
5	VDD1	4109.11	3576.38	0.1617758	0.1408024
6	VDD2	4109.11	3434.54	0.1617758	0.1352181
7	DGND3	4109.11	3085.34	0.1617758	0.1214701
8	DGND4	4109.11	2954.30	0.1617758	0.1163110
9	DOUT11	4109.11	2719.30	0.1617758	0.1070591
10	DOUT10	4109.11	2484.30	0.1617758	0.0978071
11	DOUT9	4109.11	2229.74	0.1617758	0.0877850
12	DOUT8	4109.11	1994.74	0.1617758	0.0785331
13	DOUT7	4109.11	1740.18	0.1617758	0.0685110
14	DOUT6	4109.11	1505.18	0.1617758	0.0592591
15	DGND5	4109.11	1270.18	0.1617758	0.0500071
16	DGND6	4109.11	1139.14	0.1617758	0.0448480
17	VDDQ3	4109.11	904.14	0.1617758	0.0355961
18	VDDQ4	4109.11	762.30	0.1617758	0.0300118
19	DOUT5	4109.11	527.30	0.1617758	0.0207598
20	DOUT4	4109.11	272.74	0.1617758	0.0107378
21	DOUT3	4109.11	37.74	0.1617758	0.0014858
22	DOUT2	4109.11	-216.82	0.1617758	-0.0085362
23	DOUT1	4109.11	-451.82	0.1617758	-0.0177882
24	DOUT0	4109.11	-706.38	0.1617758	-0.0278102
25	PIXCLK	4109.11	-941.38	0.1617758	-0.0370622
26	EXTCLK	4109.11	-1195.94	0.1617758	-0.0470843
27	DNU	4109.11	-1586.42	0.1617758	-0.0624575
28	DNU	4109.11	-1876.42	0.1617758	-0.0738748
29	DNU	4109.11	-2243.06	0.1617758	-0.0883094
30	DNU	4109.11	-2533.06	0.1617758	-0.0997268
31	PLLGND	4109.11	-3064.50	0.1617758	-0.1206496
32	VDDPLL	4109.11	-3299.50	0.1617758	-0.1299016
33	DNU	-3730.48	-3834.77	-0.1468693	-0.1509750
34	DNU	-3861.52	-3834.77	-0.1520283	-0.1509750
35	VAA4	-4109.11	-3576.38	-0.1617758	-0.1408024
36	VAA3	-4109.11	-3434.54	-0.1617758	-0.1352181
37	VAA2	-4109.11	-3292.70	-0.1617758	-0.1296339
38	VAA1	-4109.11	-3150.86	-0.1617758	-0.1240496
39	AGND6	-4109.11	-2915.86	-0.1617758	-0.1147976
40	AGND5	-4109.11	-2784.82	-0.1617758	-0.1096386
41	AGND4	-4109.11	-2653.78	-0.1617758	-0.1044795
42	AGND3	-4109.11	-2522.74	-0.1617758	-0.0993205



## MT9P011: 5-Megapixel CMOS Digital Image Sensor Die Bond Pad Identification Tables

**Table 2: Bond Pad Location and Identification from Center of Die (continued)**

Pad	MT9P011	"X" <sup>1</sup> Microns	"Y" <sup>1</sup> Microns	"X" <sup>1</sup> Inches	"Y" <sup>1</sup> Inches
43	TEST1 <sup>3</sup>	-4109.11	-2287.74	-0.1617758	-0.0900685
44	TEST2 <sup>3</sup>	-4109.11	-2052.74	-0.1617758	-0.0808165
45	DNU	-4109.11	-1817.74	-0.1617758	-0.0715646
46	DNU	-4109.11	-1582.74	-0.1617758	-0.0623126
47	OE#	-4109.11	-1076.74	-0.1617758	-0.0423913
48	RESET#	-4109.11	-841.74	-0.1617758	-0.0331394
49	TRIGGER	-4109.11	-606.74	-0.1617758	-0.0238874
50	STANDBY#	-4109.11	-371.74	-0.1617758	-0.0146354
51	SADDR	-4109.11	-136.74	-0.1617758	-0.0053835
52	VDD3	-4109.11	35.18	-0.1617758	0.0013850
53	VDDQ2	-4109.11	490.22	-0.1617758	0.0193000
54	VDDQ1	-4109.11	632.06	-0.1617758	0.0248843
55	DGND2	-4109.11	763.10	-0.1617758	0.0300433
56	DGND1	-4109.11	894.14	-0.1617758	0.0352024
57	STROBE	-4109.11	1086.94	-0.1617758	0.0427929
58	LINE_VALID	-4109.11	1321.94	-0.1617758	0.0520449
59	FRAME_VALID	-4109.11	1576.50	-0.1617758	0.0620669
60	RSVD <sup>4</sup>	-4109.11	1811.50	-0.1617758	0.0713189
61	SDATA	-4109.11	2046.50	-0.1617758	0.0805709
62	SCLK	-4109.11	2281.50	-0.1617758	0.0898228
63	TEST3 <sup>3</sup>	-4109.11	2766.22	-0.1617758	0.1089063
64	AGND2	-4109.11	3001.22	-0.1617758	0.1181583
65	AGND1	-4109.11	3132.26	-0.1617758	0.1233173
66	VAAPIX2	-4109.11	3367.26	-0.1617758	0.1325693
67	VAAPIX1	-4109.11	3509.10	-0.1617758	0.1381535

- Notes:
1. Reference to center of each bond pad from center of die.
  2. DNU = "do not use." See "Bonding Instructions" on page 2.
  3. TEST1-TEST3 pads must be tied to AGND for normal device operation.
  4. RSVD pad must be tied to DGND for normal device operation.





# MT9P011: 5-Megapixel CMOS Digital Image Sensor Die Die Features

## Die Features

Figure 2: Die Outline (Top View)

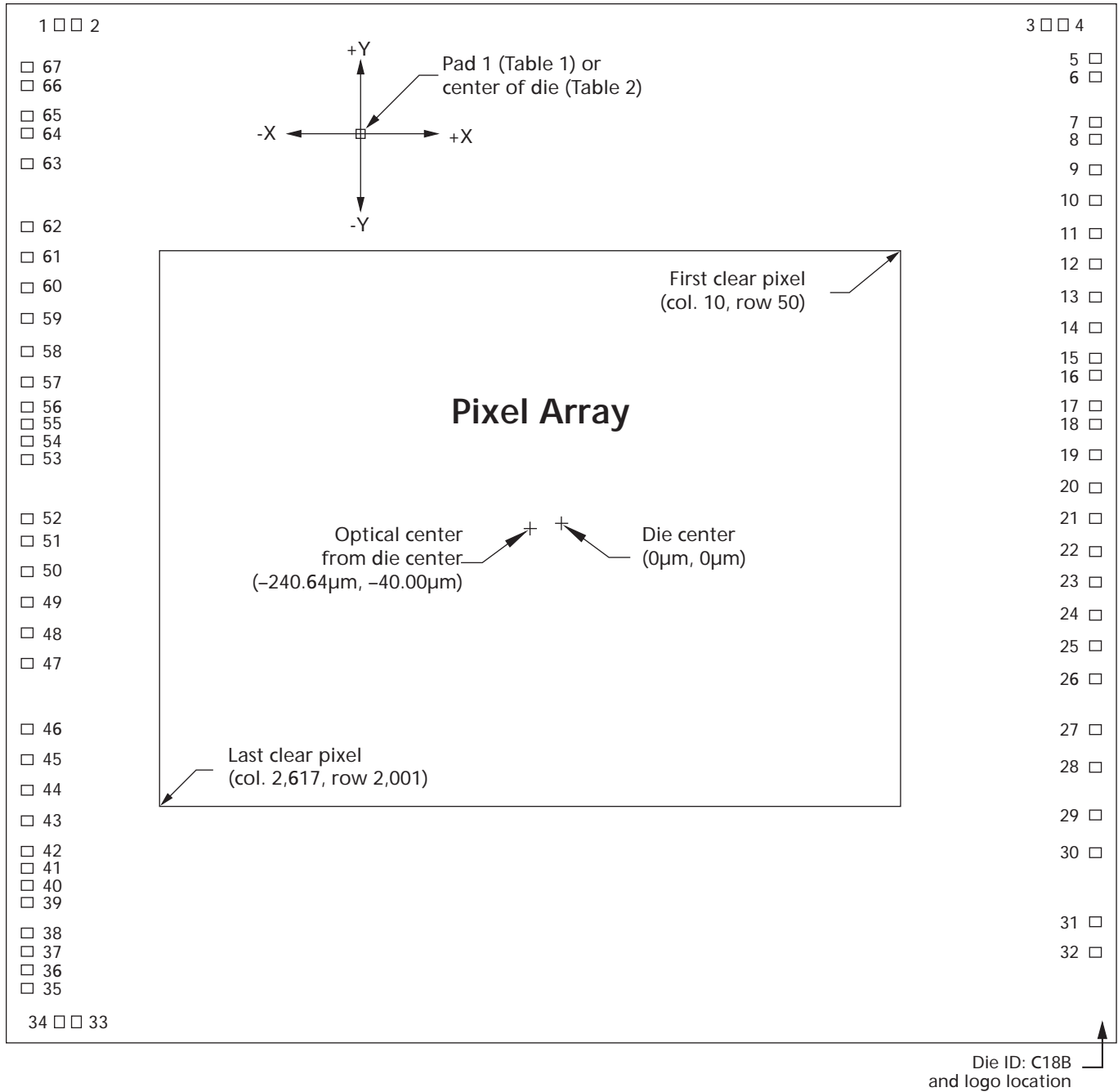



## MT9P011: 5-Megapixel CMOS Digital Image Sensor Die Physical Specifications

### Physical Specifications

Table 3: Physical Dimensions

Feature	Dimensions
Wafer diameter	200mm (8in)
Die thickness	200 $\mu$ m $\pm$ 12 $\mu$ m
Singulated die size (after wafer saw) Width (X dimension): Length (Y dimension):	8,499 $\pm$ 25 $\mu$ m 7,950 $\pm$ 25 $\mu$ m
Bond pad size (MIN)	85 $\mu$ m x 100 $\mu$ m (3.35 mil x 3.94 mil)
Passivation openings (MIN)	75 $\mu$ m x 90 $\mu$ m (2.95 mil x 3.54 mil)
Minimum bond pad pitch	131 $\mu$ m (5.16 mil)
Center of pad 1 to center of die	X = 3,861.520 $\mu$ m, Y = -3,834.765
Optical array Optical center from die center: Optical center from center of pad 1:	X = -240.64 $\mu$ m, Y = -40.00 $\mu$ m X = 3,620.88 $\mu$ m, Y = -3,874.77 $\mu$ m
First clear pixel (col. 10, row 50) From die center: From center of pad 1:	X = 2,622.88 $\mu$ m, Y = 2,106.08 $\mu$ m X = 6,484.40 $\mu$ m, Y = -1,728.69 $\mu$ m
Last clear pixel (col. 2,617, row 2,001) From die center: From center of pad 1:	X = -3,112.96 $\mu$ m, Y = -2,186.08 $\mu$ m X = 748.56 $\mu$ m, Y = -6,020.85 $\mu$ m



# MT9P011: 5-Megapixel CMOS Digital Image Sensor Die Physical Specifications

**Figure 3: Die Orientation in Reconstructed Wafer**

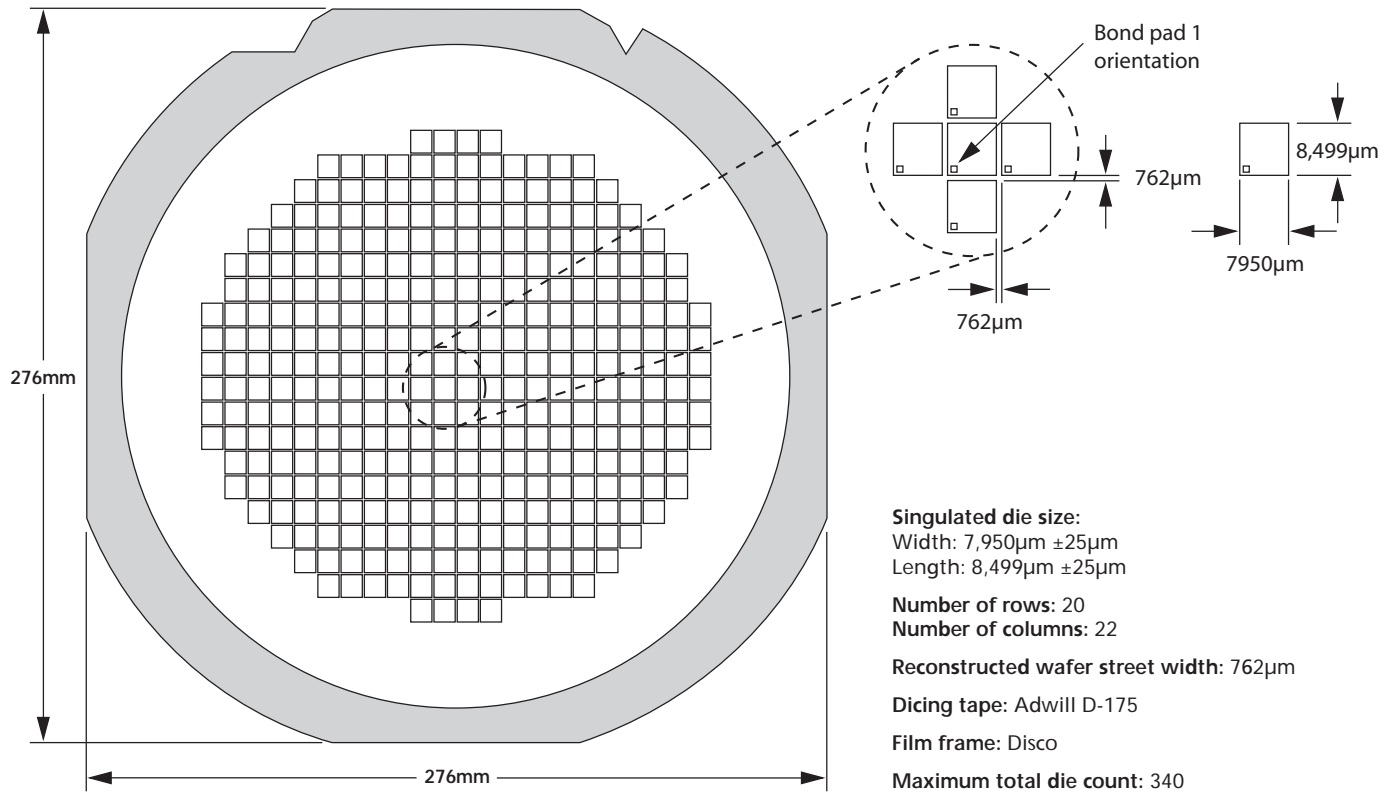

8000 S. Federal Way, P.O. Box 6, Boise, ID 83707-0006, Tel: 208-368-3900  
 prodmktg@micron.com www.micron.com Customer Comment Line: 800-932-4992  
 Micron, the M logo, the Micron logo, and DigitalClarity are trademarks of Micron Technology, Inc.  
 All other trademarks are the property of their respective owners.

**Preliminary: This data sheet contains initial characterization limits that are subject to change upon full characterization of production devices.**



**MT9P011: 5-Megapixel CMOS Digital Image Sensor Die  
Revision History**

**Revision History**

**Rev. E** ..... **4/07**

- Updated Figure 3 on page 11

**Rev. D** ..... **12/06**

- Corrected Table 2 title and coordinates

**Rev. C** ..... **10/06**

- Changed part number from MT9P001 to MT9P011

**Rev. B** ..... **5/06**

- Changed pad CLKIN to EXTCLK
- Changed status from Advance to Preliminary
- Changed maximum data rate/master clock to  
96 Mp/s at 96 MHz (2.8V I/O)  
48 Mp/s at 48 MHz (1.8V I/O), page 1
- Changed frame rate to:  
Full resolution, programmable up to 14 fps  
VGA (640 x 480, with binning), programmable up to 53 fps, pages 1 and 3
- Changed responsivity to 1.4 V/lux-sec (550nm), page 1
- Changed pixel dynamic range to 70.1dB, page 1
- Changed SNRMAX to 38.1dB, page 1

**Rev. A** ..... **2/06**

- Initial release, Advance