



# 1/3-Inch Wide-VGA CMOS Digital Image Sensor

## MT9V024

For the latest data sheet revision, refer to Aptina's Web site: [www.aplina.com](http://www.aplina.com)

### Features

- DigitalClarity<sup>®</sup> CMOS imaging technology
- Array format: Wide-VGA, active 752H x 480V (360,960 pixels)
- TrueSNAP<sup>™</sup> global shutter photodiode pixels; simultaneous integration and readout
- Monochrome or color: NIR enhanced performance for use with non-visible NIR illumination
- Readout modes: progressive or interlaced
- Shutter efficiency: >99%
- Simple two-wire serial interface
- Real-time exposure context switching - dual register set
- Register lock capability
- Window size: User programmable to any smaller format (QVGA, CIF, QCIF). Data rate can be maintained independent of window size
- Binning: 2 x 2 and 4 x 4 of the full resolution
- ADC: On-chip, 10-bit column-parallel (option to operate in 12-bit to 10-bit companding mode)
- Automatic controls: Auto exposure control (AEC) and auto gain control (AGC); variable regional and variable weight AEC/AGC
- Support for four unique serial control register IDs to control multiple imagers on the same bus
- Data output formats:
  - Single sensor mode:
    - 10-bit parallel/stand-alone
    - 8-bit or 10-bit serial LVDS
  - Stereo sensor mode:
    - Interspersed 8-bit serial LVDS
- High dynamic range (HDR) mode

### Applications

- Automotive
- Unattended surveillance
- Stereo vision
- Smart vision
- Automation
- Video as input
- Machine vision

**Table 1: Key Performance Parameters**

Parameter	Value
Optical format	1/3-inch
Active imager size	4.51mm(H) x 2.88mm(V) 5.35mm diagonal
Active pixels	752H x 480V
Pixel size	6.0 x 6.0 $\mu$ m
Color filter array	Monochrome or color RGB Bayer pattern
Shutter type	TrueSNAP <sup>™</sup> Global shutter
Maximum data rate	27 Mp/s
master clock	27 MHz
Full resolution	752 x 480
Frame rate	60 fps (at full resolution)
ADC resolution	10-bit column-parallel
Responsivity	4.8 V/lux-sec (550nm)
Dynamic range	>55dB linear; >100dB in HDR mode
Supply voltage	3.3V $\pm$ 0.3V (all supplies)
Power consumption	<160mW at maximum data rate (LVDS disabled); 120 $\mu$ W standby power at 3.3V
Operating temperature	-40°C to +105°C ambient
Packaging	52-ball IBGA, automotive-qualified; wafer or die

### Ordering Information

**Table 2: Available Part Numbers**

Part Number	Description
MT9V024IA7XTC	IBGA RoHS-compliant color sensor
MT9V024IA7XTM	IBGA RoHS-compliant monochrome
MT9V024IA7XTCD ES	Color Demo Kit (Pb-free)
MT9V024IA7XTCH ES	Color Headboard (Pb-free)
MT9V024IA7XTMD ES	Monochrome Demo Kit (Pb-free)
MT9V024IA7XTMH ES	Monochrome Headboard (Pb-free)



## Table of Contents

Features . . . . .	1
Applications . . . . .	1
Ordering Information . . . . .	1
General Description . . . . .	6
Ball Descriptions . . . . .	8
Pixel Data Format . . . . .	10
Pixel Array Structure . . . . .	10
Color Device Limitations . . . . .	12
Pixel Binning . . . . .	12
Interlaced Readout . . . . .	12
Automatic Black Level Calibration . . . . .	12
Defective Pixel Correction . . . . .	12
Other Limiting Factors . . . . .	12
Output Data Format . . . . .	13
Output Data Timing . . . . .	14
Serial Bus Description . . . . .	16
Protocol . . . . .	16
Start Bit . . . . .	16
Slave Address . . . . .	16
Acknowledge Bit . . . . .	16
No-Acknowledge Bit . . . . .	16
Stop Bit . . . . .	16
Sequence . . . . .	17
Bus Idle State . . . . .	17
Data Bit Transfer . . . . .	17
Two-Wire Serial Interface Sample Read and Write Sequences . . . . .	18
16-Bit Write Sequence . . . . .	18
16-Bit Read Sequence . . . . .	18
8-Bit Write Sequence . . . . .	19
8-Bit Read Sequence . . . . .	19
Register Lock . . . . .	20
Lock All Registers . . . . .	20
Lock Only Read Mode Registers (R0x0D and R0x0E) . . . . .	20
Real-Time Context Switching . . . . .	21
Registers . . . . .	22
Shadowed Registers . . . . .	26
Feature Description . . . . .	48
Operational Modes . . . . .	48
Master Mode . . . . .	48
Simultaneous Master Mode . . . . .	48
Sequential Master Mode . . . . .	49
Snapshot Mode . . . . .	49
Slave Mode . . . . .	50
Signal Path . . . . .	51
On-Chip Biases . . . . .	51
ADC Voltage Reference . . . . .	51
V_Step Voltage Reference . . . . .	51
Chip Version . . . . .	51
Window Control . . . . .	51
Blanking Control . . . . .	52
Pixel Integration Control . . . . .	53



Total Integration . . . . .	.53
Row Timing. . . . .	.53
High Dynamic Range . . . . .	.55
ADC Companding Mode. . . . .	.57
Gain Settings . . . . .	.58
Changes to Gain Settings . . . . .	.58
Analog Gain . . . . .	.58
Digital Gain . . . . .	.59
Black Level Calibration . . . . .	.60
Defective Pixel Correction . . . . .	.61
Row-wise Noise Correction . . . . .	.61
Automatic Gain Control and Automatic Exposure Control . . . . .	.62
Pixel Clock Speed . . . . .	.63
Hard Reset of Logic . . . . .	.63
Soft Reset of Logic . . . . .	.63
STANDBY Control . . . . .	.63
Monitor Mode Control . . . . .	.63
Read Mode Options . . . . .	.64
Column Flip . . . . .	.64
Row Flip . . . . .	.64
Pixel Binning. . . . .	.64
Row Binning . . . . .	.65
Column Binning . . . . .	.65
Interlaced Readout . . . . .	.66
LINE_VALID . . . . .	.68
LVDS Serial (Stand-Alone/Stereo) Output . . . . .	.68
LVDS Output Format. . . . .	.69
LVDS Enable and Disable. . . . .	.71
LVDS Data Bus Timing . . . . .	.72
Electrical Specifications. . . . .	.73
Propagation Delays for PIXCLK and Data Out Signals. . . . .	.75
Propagation Delays for FRAME_VALID and LINE_VALID Signals . . . . .	.75
Two-Wire Serial Bus Timing . . . . .	.76
Minimum Master Clock Cycles . . . . .	.77
Package Dimensions . . . . .	.80
Appendix A – Power-On Reset and Standby Timing . . . . .	.81
Revision History. . . . .	.82



## List of Figures

Figure 1:	Block Diagram	6
Figure 2:	52-Ball IBGA Package	7
Figure 3:	Typical Configuration (Connection)—Parallel Output Mode	9
Figure 4:	Pixel Array Description	10
Figure 5:	Pixel Color Pattern Detail (Top Right Corner)	11
Figure 6:	Spatial Illustration of Image Readout	13
Figure 7:	Timing Example of Pixel Data	14
Figure 8:	Row Timing and FRAME_VALID/LINE_VALID Signals	14
Figure 9:	Timing Diagram Showing a Write to R0x09 with the Value 0x0284	18
Figure 10:	Timing Diagram Showing a Read from R0x09; Returned Value 0x0284	18
Figure 11:	Timing Diagram Showing a Byte-wise Write to R0x09 with the Value 0x0284	19
Figure 12:	Timing Diagram Showing a Byte-wise Read from R0x09; Returned Value 0x0284	19
Figure 13:	Simultaneous Master Mode Synchronization Waveforms #1	48
Figure 14:	Simultaneous Master Mode Synchronization Waveforms #2	48
Figure 15:	Sequential Master Mode Synchronization Waveforms	49
Figure 16:	Snapshot Mode Interface Signals	49
Figure 17:	Snapshot Mode Frame Synchronization Waveforms	50
Figure 18:	Slave Mode Operation	50
Figure 19:	Signal Path	51
Figure 20:	Latency When Changing Integration	54
Figure 21:	Sequence of Control Voltages at the HDR Gate	55
Figure 22:	Sequence of Voltages in a Piecewise Linear Pixel Response	56
Figure 23:	12- to 10-Bit Companding Chart	57
Figure 24:	Latency of Analog Gain Change When AGC Is Disabled	58
Figure 25:	Tiled Sample	59
Figure 26:	Black Level Calibration Flow Chart	60
Figure 27:	Controllable and Observable AEC/AGC Registers	62
Figure 28:	Readout of Six Pixels in Normal and Column Flip Output Mode	64
Figure 29:	Readout of Six Rows in Normal and Row Flip Output Mode	64
Figure 30:	Readout of 8 Pixels in Normal and Row Bin Output Mode	65
Figure 31:	Readout of 8 Pixels in Normal and Column Bin Output Mode	66
Figure 32:	Spatial Illustration of Interlaced Image Readout	67
Figure 33:	Different LINE_VALID Formats	68
Figure 34:	Serial Output Format for a 6x2 Frame	69
Figure 35:	LVDS Timing	72
Figure 36:	Propagation Delays for PIXCLK and Data Out Signals	75
Figure 37:	Propagation Delays for FRAME_VALID and LINE_VALID Signals	75
Figure 38:	Two-wire Serial Bus Timing	76
Figure 39:	Serial Host Interface Start Condition Timing	77
Figure 40:	Serial Host Interface Stop Condition Timing	77
Figure 41:	Serial Host Interface Data Timing for WRITE	77
Figure 42:	Serial Host Interface Data Timing for READ	78
Figure 43:	Acknowledge Signal Timing After an 8-Bit WRITE to the Sensor	78
Figure 44:	Acknowledge Signal Timing After an 8-Bit READ from the Sensor	78
Figure 45:	Typical Quantum Efficiency—Color	79
Figure 46:	Typical Quantum Efficiency—Monochrome	79
Figure 47:	52-Ball IBGA	80
Figure 48:	Power-up, Reset, Clock, and Standby Sequence	81



## List of Tables

Table 1:	Key Performance Parameters . . . . .	1
Table 2:	Available Part Numbers . . . . .	1
Table 3:	Ball Descriptions . . . . .	8
Table 4:	Frame Time . . . . .	14
Table 5:	Frame Time—Long Integration Time . . . . .	15
Table 6:	Slave Address Modes . . . . .	17
Table 7:	Real-Time Context-Switchable Registers . . . . .	21
Table 8:	Default Register Descriptions . . . . .	22
Table 9:	Register Descriptions . . . . .	26
Table 10:	LVDS Packet Format in Stand-Alone Mode . . . . .	69
Table 11:	LVDS Packet Format in Stereoscopy Mode (Stereoscopy Mode Bit Asserted) . . . . .	70
Table 12:	Reserved Words in the Pixel Data Stream . . . . .	70
Table 13:	SER_DATAOUT_* state . . . . .	71
Table 14:	SHFT_CLK_* state . . . . .	71
Table 15:	LVDS AC Timing Specifications . . . . .	72
Table 16:	DC Electrical Characteristics Over Temperature . . . . .	73
Table 17:	DC Electrical Characteristics . . . . .	73
Table 18:	Absolute Maximum Ratings . . . . .	74
Table 19:	AC Electrical Characteristics . . . . .	74
Table 20:	Two-Wire Serial Bus Timing Parameters . . . . .	76

## General Description

The MT9V024 is a 1/3-inch wide-VGA format CMOS active-pixel digital image sensor with TrueSNAP™ global shutter and high dynamic range (HDR) operation. The sensor has specifically been designed to support the demanding interior and exterior automotive imaging needs, which makes this part ideal for a wide variety of imaging applications in real-world environments.

This wide-VGA CMOS image sensor features DigitalClarity—Aptina’s breakthrough low-noise CMOS imaging technology that achieves CCD image quality (based on signal-to-noise ratio and low-light sensitivity) while maintaining the inherent size, cost, and integration advantages of CMOS.

The active imaging pixel array is 752H x 480V. It incorporates sophisticated camera functions on-chip—such as binning 2 x 2 and 4 x 4, to improve sensitivity when operating in smaller resolutions—as well as windowing, column and row mirroring. It is programmable through a simple two-wire serial interface.

The MT9V024 can be operated in its default mode or be programmed for frame size, exposure, gain setting, and other parameters. The default mode outputs a wide-VGA-size image at 60 frames per second (fps).

An on-chip analog-to-digital converter (ADC) provides 10 bits per pixel. A 12-bit resolution companded for 10 bits for small signals can be alternatively enabled, allowing more accurate digitization for darker areas in the image.

In addition to a traditional, parallel logic output the MT9V024 also features a serial low-voltage differential signaling (LVDS) output. The sensor can be operated in a stereo-camera, and the sensor, designated as a stereo-master, is able to merge the data from itself and the stereo-slave sensor into one serial LVDS stream.

The sensor is designed to operate in a wide temperature range (–40°C to +105°C).

**Figure 1: Block Diagram**

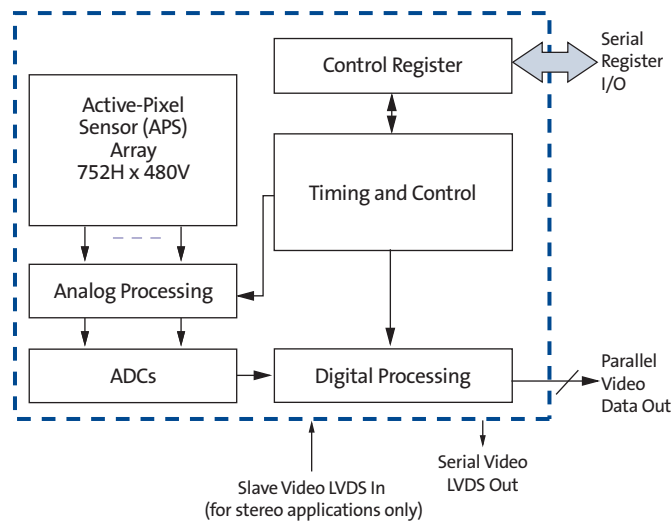
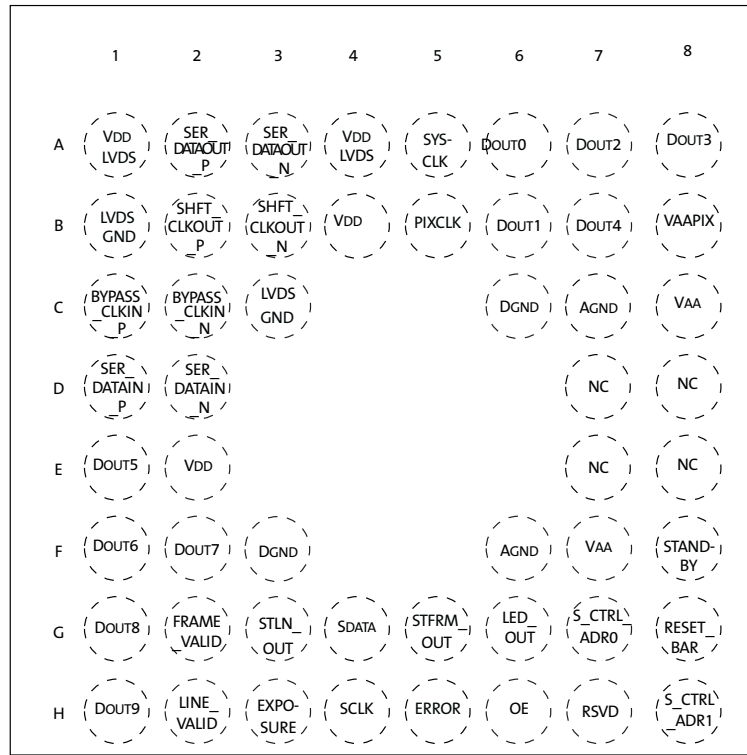


Figure 2: 52-Ball IBGA Package



Top View  
(Ball Down)



## Ball Descriptions

Table 3: Ball Descriptions

52-Ball IBA Numbers	Symbol	Type	Description	Note
H7	RSVD	Input	Connect to DGND.	1
D2	SER_DATAIN_N	Input	Serial data in for stereoscopy (differential negative). Tie to 1K $\Omega$ pull-up (to 3.3V) in non-stereoscopy mode.	
D1	SER_DATAIN_P	Input	Serial data in for stereoscopy (differential positive). Tie to DGND in non-stereoscopy mode.	
C2	BYPASS_CLKIN_N	Input	Input bypass shift-CLK (differential negative). Tie to 1K $\Omega$ pull-up (to 3.3V) in non-stereoscopy mode.	
C1	BYPASS_CLKIN_P	Input	Input bypass shift-CLK (differential positive). Tie to DGND in non-stereoscopy mode.	
H3	EXPOSURE	Input	Rising edge starts exposure in snapshot and slave modes.	
H4	SCLK	Input	Two-wire serial interface clock. Connect to VDD with 1.5K resistor even when no other two-wire serial interface peripheral is attached.	
H6	OE	Input	DOUT enable pad, active HIGH.	2
G7	S_CTRL_ADR0	Input	Two-wire serial interface slave address select (see Table 6 on page 17).	
H8	S_CTRL_ADR1	Input	Two-wire serial interface slave address select (see Table 6 on page 17).	
G8	RESET_BAR	Input	Asynchronous reset. All registers assume defaults.	
F8	STANDBY	Input	Shut down sensor operation for power saving.	
A5	SYCLK	Input	Master clock (26.6 MHz; 13 MHz – 27 MHz).	
G4	SDATA	I/O	Two-wire serial interface data. Connect to VDD with 1.5K resistor even when no other two-wire serial interface peripheral is attached.	
G3	STLN_OUT	I/O	Output in master mode—start line sync to drive slave chip in-phase; input in slave mode.	
G5	STFRM_OUT	I/O	Output in master mode—start frame sync to drive a slave chip in-phase; input in slave mode.	
H2	LINE_VALID	Output	Asserted when DOUT data is valid.	
G2	FRAME_VALID	Output	Asserted when DOUT data is valid.	
E1	DOUT5	Output	Parallel pixel data output 5.	
F1	DOUT6	Output	Parallel pixel data output 6.	
F2	DOUT7	Output	Parallel pixel data output 7.	
G1	DOUT8	Output	Parallel pixel data output 8	
H1	DOUT9	Output	Parallel pixel data output 9.	
H5	ERROR	Output	Error detected. Directly connected to STEREO ERROR FLAG.	
G6	LED_OUT	Output	LED strobe output.	
B7	DOUT4	Output	Parallel pixel data output 4.	
A8	DOUT3	Output	Parallel pixel data output 3.	
A7	DOUT2	Output	Parallel pixel data output 2.	
B6	DOUT1	Output	Parallel pixel data output 1.	
A6	DOUT0	Output	Parallel pixel data output 0.	
B5	PIXCLK	Output	Pixel clock out. DOUT is valid on rising edge of this clock.	
B3	SHFT_CLKOUT_N	Output	Output shift CLK (differential negative).	
B2	SHFT_CLKOUT_P	Output	Output shift CLK (differential positive).	
A3	SER_DATAOUT_N	Output	Serial data out (differential negative).	
A2	SER_DATAOUT_P	Output	Serial data out (differential positive).	

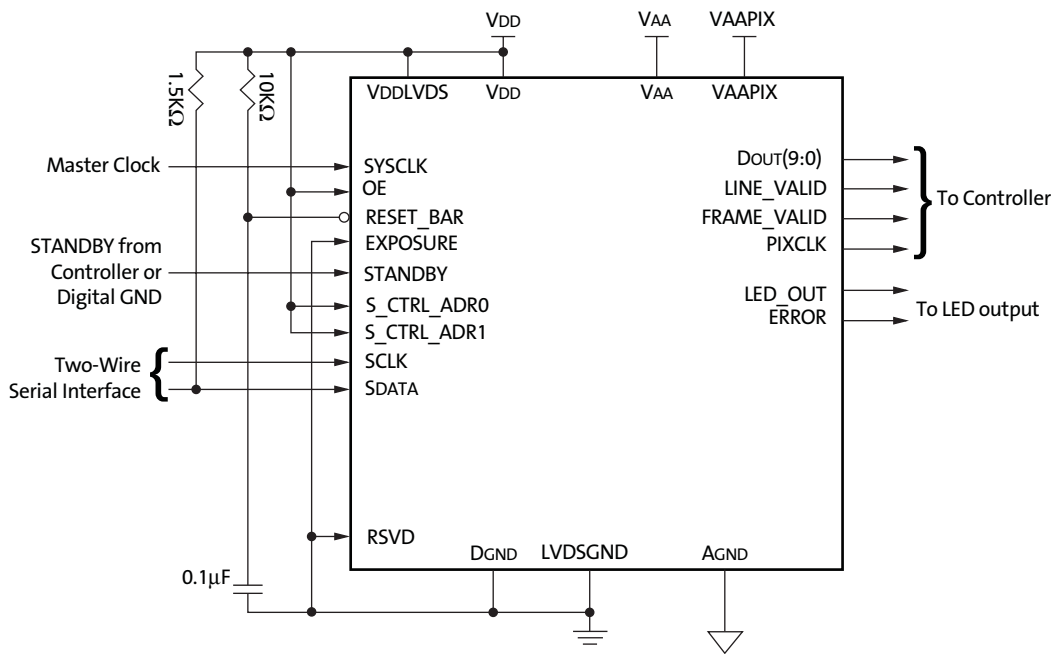


Table 3: Ball Descriptions (continued)

52-Ball IBA Numbers	Symbol	Type	Description	Note
B4, E2	VDD	Supply	Digital power 3.3V.	
C8, F7	VAA	Supply	Analog power 3.3V.	
B8	VAAPIX	Supply	Pixel power 3.3V.	
A1, A4	VDDLVD5	Supply	Dedicated power for LVDS pads.	
B1, C3	LVDSGND	Ground	Dedicated GND for LVDS pads.	
C6, F3	DGND	Ground	Digital GND.	
C7, F6	AGND	Ground	Analog GND.	
E7, E8, D7, D8	NC	NC	No connect.	3

- Notes:
1. Pin H7 (RSVD) must be tied to GND.
  2. Output enable (OE) tri-states signals DOUT0–DOUT9, LINE\_VALID, FRAME\_VALID, and PIXCLK.
  3. No connect. These pins must be left floating for proper operation.

Figure 3: Typical Configuration (Connection)—Parallel Output Mode



Note: LVDS signals are to be left floating.

## Pixel Data Format

### Pixel Array Structure

The MT9V024 pixel array is configured as 809 columns by 499 rows, shown in Figure 4. The dark pixels are optically black and are used internally to monitor black level. Of the left 52 columns, 36 are dark pixels used for row noise correction. Of the top 14 rows of pixels, two of the dark rows are used for black level correction. Also, three black rows from the top black rows can be read out by setting the show dark rows bit in the Read Mode register; setting show dark columns will display the 36 dark columns. There are 753 columns by 481 rows of optically active pixels. While the sensor's format is 752 x 480, one additional active column and active row are included for use when horizontal or vertical mirrored readout is enabled, to allow readout to start on the same pixel. This one pixel adjustment is always performed, for monochrome or color versions. The active area is surrounded with optically transparent dummy pixels to improve image uniformity within the active area. Neither dummy pixels nor barrier pixels can be read out.

Figure 4: Pixel Array Description

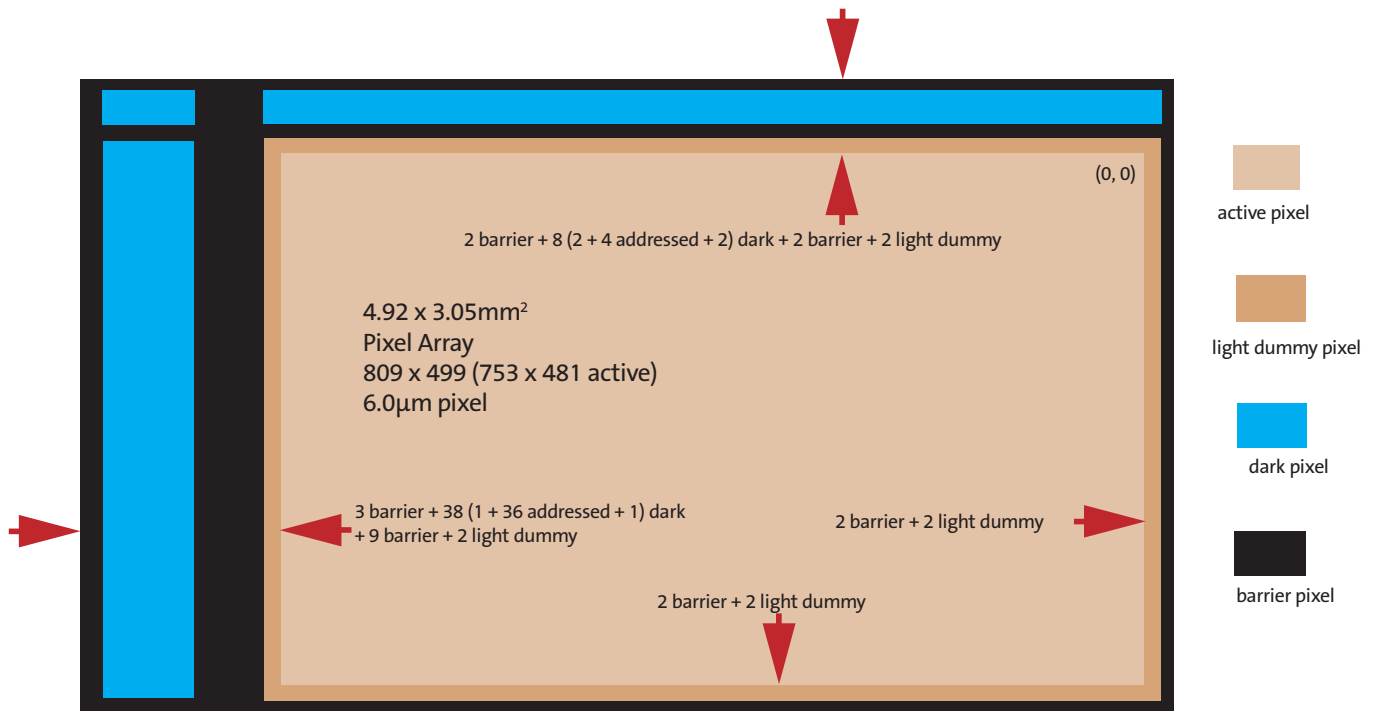
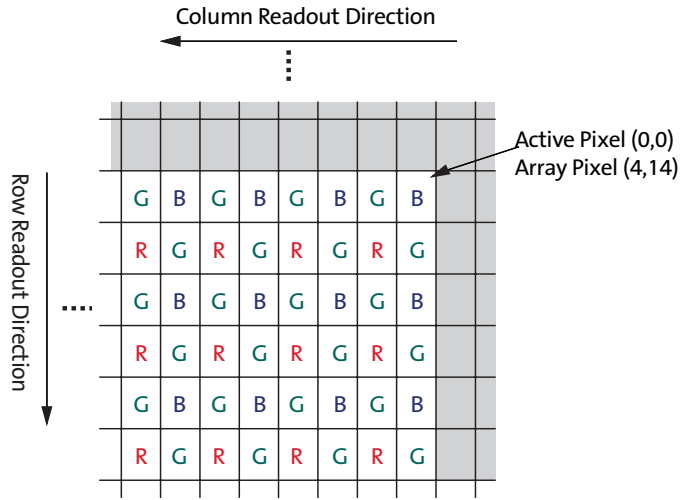


Figure 5: Pixel Color Pattern Detail (Top Right Corner)





## Color Device Limitations

The color version of the MT9V024 does not support or offers reduced performance for the following functionalities.

### Pixel Binning

Pixel binning is done on immediate neighbor pixels only, no facility is provided to skip pixels according to a Bayer pattern. Therefore, the result of binning combines pixels of different colors. See “Pixel Binning” on page 64 for additional information.

### Interlaced Readout

Interlaced readout yields one field consisting only of red and green pixels and another consisting only of blue and green pixels. This is due to the Bayer pattern of the CFA.

### Automatic Black Level Calibration

When the color bit is set ( $R0x0F[1]=1$ ), the sensor uses black level correction values from one green plane, which are applied to all colors. To use the calibration value based on all dark pixels' offset values, the color bit should be cleared.

### Defective Pixel Correction

For defective pixel correction to calculate replacement pixel values correctly, for color sensors the color bit must be set ( $R0x0F[1] = 1$ ). However, the color bit also applies unequal offset to the color planes, and the results might not be acceptable for some applications.

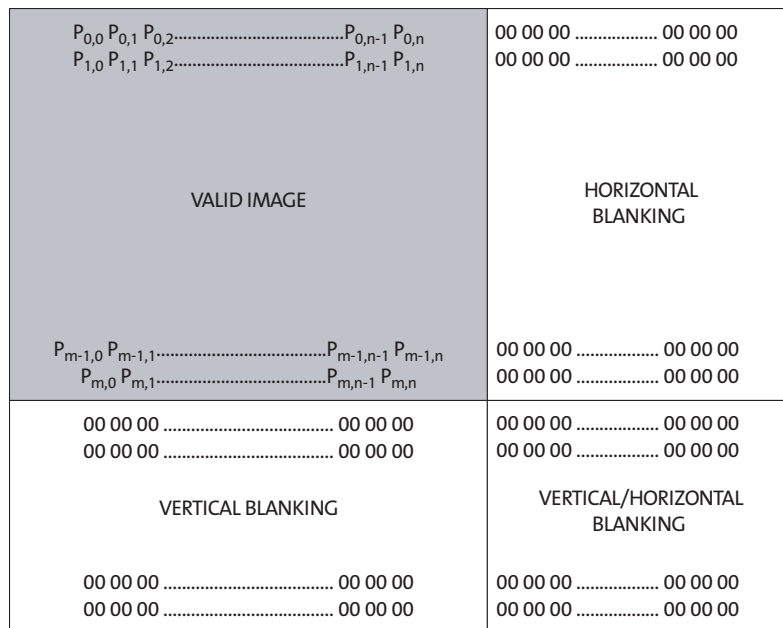
### Other Limiting Factors

Black level correction and row-wise noise correction are applied uniformly to each color. The row-wise noise correction algorithm does not work well in color sensors. Automatic exposure and gain control calculations are made based on all three colors, not just the green channel. High dynamic range does operate in color; however, Aptina strongly recommends limiting use to linear operation where good color fidelity is required.

## Output Data Format

The MT9V024 image data can be read out in a progressive scan or interlaced scan mode. Valid image data is surrounded by horizontal and vertical blanking, as shown in Figure 6. The amount of horizontal and vertical blanking is programmable through R0x05 and R0x06, respectively (R0xCD and R0xCE for context B). LV is HIGH during the shaded region of the figure. See “Output Data Timing” on page 14 for the description of FV timing.

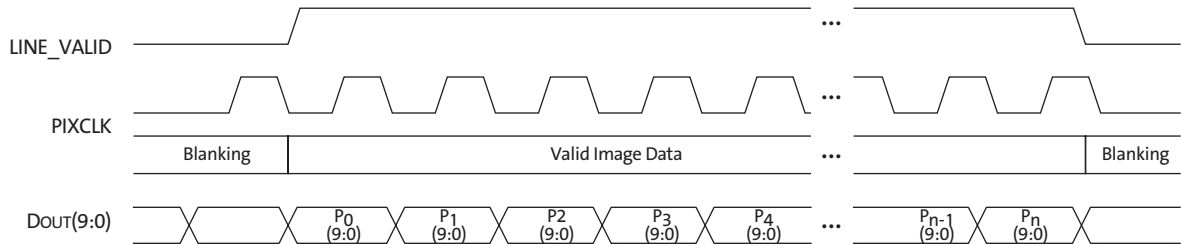
Figure 6: Spatial Illustration of Image Readout



## Output Data Timing

The data output of the MT9V024 is synchronized with the PIXCLK output. When LINE\_VALID (LV) is HIGH, one 10-bit pixel datum is output every PIXCLK period.

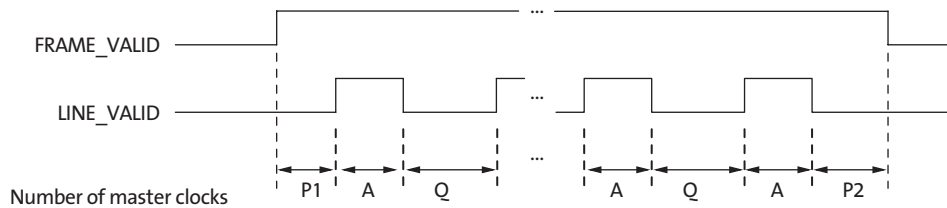
**Figure 7: Timing Example of Pixel Data**



The PIXCLK is a nominally inverted version of the master clock (SYSCLK). This allows PIXCLK to be used as a clock to latch the data. However, when column bin 2 is enabled, the PIXCLK is HIGH for one complete master clock period and then LOW for one complete master clock period; when column bin 4 is enabled, the PIXCLK is HIGH for two complete master clock periods and then LOW for two complete master clock periods. It is continuously enabled, even during the blanking period. Setting R0x72 bit[4] = 1 causes the MT9V024 to invert the polarity of the PIXCLK.

The parameters P1, A, Q, and P2 in Figure 8 are defined in Table 4.

**Figure 8: Row Timing and FRAME\_VALID/LINE\_VALID Signals**



**Table 4: Frame Time**

Parameter	Name	Equation	Default Timing at 26.66 MHz
A	Active data time	Context A: R0x04 Context B: R0xCC	752 pixel clocks = 752 master = 28.20µs
P1	Frame start blanking	Context A: R0x05 - 23 Context B: R0xCD - 23	71 pixel clocks = 71 master = 2.66µs
P2	Frame end blanking	23 (fixed)	23 pixel clocks = 23 master = 0.86µs
Q	Horizontal blanking	Context A: R0x05 Context B: R0xCD	94 pixel clocks = 94 master = 3.52µs



Table 4: Frame Time (continued)

Parameter	Name	Equation	Default Timing at 26.66 MHz
A+Q	Row time	Context A: R0x04 + R0x05 Context B: R0xCC + R0xCD	846 pixel clocks = 846 master = 31.72μs
V	Vertical blanking	Context A: (R0x06) x (A + Q) + 4 Context B: (R0xCE) x (A + Q) + 4	38,074 pixel clocks = 38,074 master = 1.43ms
Nrows x (A + Q)	Frame valid time	Context A: (R0x03) x (A + Q) Context B: (R0xCB) x (A + Q)	406,080 pixel clocks = 406,080 master = 15.23ms
F	Total frame time	V + (Nrows x (A + Q))	444,154 pixel clocks = 444,154 master = 16.66ms

Sensor timing is shown above in terms of pixel clock and master clock cycles (refer to Figure 7 on page 14). The recommended master clock frequency is 26.66 MHz. The vertical blanking and the total frame time equations assume that the integration time (coarse shutter width plus fine shutter width) is less than the number of active rows plus the blanking rows minus the overhead rows:

$$\text{Window Height} + \text{Vertical Blanking} - 2 \quad (EQ 1)$$

If this is not the case, the number of integration rows must be used instead to determine the frame time, as shown in Table 5. In this example, it is assumed that the coarse shutter width control is programmed with 523 rows and the fine shutter width total is zero.

For Simultaneous mode, if the exposure time registers (coarse shutter width total plus Fine Shutter Width Total) exceed the total readout time, then the vertical blanking time is internally extended automatically to adjust for the additional integration time required. This extended value is **not** written back to the vertical blanking registers. The vertical blank register can be used to adjust frame-to-frame readout time. This register does not affect the exposure time but it may extend the readout time.

Table 5: Frame Time—Long Integration Time

Parameter	Name	Equation (Number of Master Clock Cycles)	Default Timing at 26.66 MHz
V'	Vertical blanking (long integration time)	Context A: (R0x0B + 2 - R0x03) x (A + Q) + R0xD5 + 4 Context B: (R0xD2 + 2 - R0xCB) x (A + Q) + R0xD8 + 4	38,074 pixel clocks = 38,074 master = 1.43ms
F'	Total frame time (long integration time)	Context A: (R0x0B + 2) x (A + Q) + R0xD5 + 4 Context B: (R0xD2 + 2) x (A + Q) + R0xD8 + 4	444,154 pixel clocks = 444,154 master = 16.66ms

Note: The MT9V024 uses column parallel analog-digital converters; thus short row timing is not possible. The minimum total row time is 690 columns (horizontal width + horizontal blanking). The minimum horizontal blanking is 61. When the window width is set below 627, horizontal blanking must be increased.



## Serial Bus Description

Registers are written to and read from the MT9V024 through the two-wire serial interface bus. The MT9V024 is a serial interface slave with four possible IDs (0x90, 0x98, 0xB0 and 0xB8) determined by the S\_CTRL\_ADR0 and S\_CTRL\_ADR1 input pins. Data is transferred into the MT9V024 and out through the serial data (SDATA) line. The SDATA line is pulled up to VDD off-chip by a 1.5KΩ resistor. Either the slave or master device can pull the SDATA line down—the serial interface protocol determines which device is allowed to pull the SDATA line down at any given time. The registers are 16-bit wide, and can be accessed through 16- or 8-bit two-wire serial interface sequences.

### Protocol

The two-wire serial interface defines several different transmission codes, as shown in the following sequence:

1. a start bit
2. the slave device 8-bit address
3. a(n) (no) acknowledge bit
4. an 8-bit message
5. a stop bit

### Start Bit

The start bit is defined as a HIGH-to-LOW transition of the data line while the clock line is HIGH.

### Slave Address

The 8-bit address of a two-wire serial interface device consists of 7 bits of address and 1 bit of direction. A “0” in the LSB of the address indicates write mode, and a “1” indicates read mode. As indicated above, the MT9V024 allows four possible slave addresses determined by the two input pins, S\_CTRL\_ADR0 and S\_CTRL\_ADR1.

### Acknowledge Bit

The master generates the acknowledge clock pulse. The transmitter (which is the master when writing, or the slave when reading) releases the data line, and the receiver indicates an acknowledge bit by pulling the data line LOW during the acknowledge clock pulse.

### No-Acknowledge Bit

The no-acknowledge bit is generated when the data line is not pulled down by the receiver during the acknowledge clock pulse. A no-acknowledge bit is used to terminate a read sequence.

### Stop Bit

The stop bit is defined as a LOW-to-HIGH transition of the data line while the clock line is HIGH.



## Sequence

A typical READ or WRITE sequence begins by the master sending a start bit. After the start bit, the master sends the slave device's 8-bit address. The last bit of the address determines if the request is a read or a write, where a "0" indicates a WRITE and a "1" indicates a READ. The slave device acknowledges its address by sending an acknowledge bit back to the master.

If the request was a WRITE, the master then transfers the 8-bit register address to which a WRITE should take place. The slave sends an acknowledge bit to indicate that the register address has been received. The master then transfers the data 8 bits at a time, with the slave sending an acknowledge bit after each 8 bits. The MT9V024 uses 16-bit data for its internal registers, thus requiring two 8-bit transfers to write to one register. After 16 bits are transferred, the register address is automatically incremented, so that the next 16 bits are written to the next register address. The master stops writing by sending a start or stop bit.

A typical READ sequence is executed as follows. First the master sends the write mode slave address and 8-bit register address, just as in the write request. The master then sends a start bit and the read mode slave address. The master then clocks out the register data 8 bits at a time. The master sends an acknowledge bit after each 8-bit transfer. The register address is automatically incremented after every 16 bits is transferred. The data transfer is stopped when the master sends a no-acknowledge bit. The MT9V024 allows for 8-bit data transfers through the two-wire serial interface by writing (or reading) the most significant 8 bits to the register and then writing (or reading) the least significant 8 bits to byte-wise address register (0x0F0).

## Bus Idle State

The bus is idle when both the data and clock lines are HIGH. Control of the bus is initiated with a start bit, and the bus is released with a stop bit. Only the master can generate the start and stop bits.

**Table 6: Slave Address Modes**

{S_CTRL_ADR1, S_CTRL_ADR0}	Slave Address	Write/Read Mode
00	0x90	Write
	0x91	Read
01	0x98	Write
	0x99	Read
10	0xB0	Write
	0xB1	Read
11	0xB8	Write
	0xB9	Read

## Data Bit Transfer

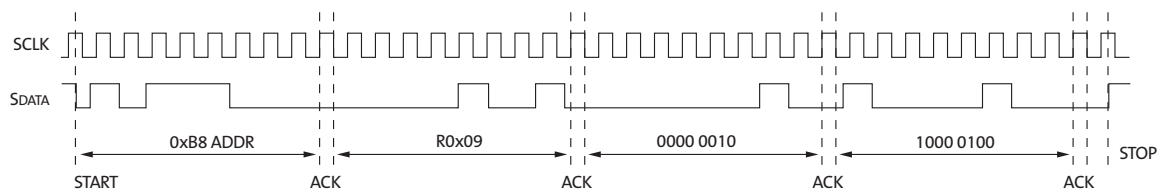
One data bit is transferred during each clock pulse. The two-wire serial interface clock pulse is provided by the master. The data must be stable during the HIGH period of the serial clock—it can only change when the two-wire serial interface clock is LOW. Data is transferred 8 bits at a time, followed by an acknowledge bit.

## Two-Wire Serial Interface Sample Read and Write Sequences

### 16-Bit Write Sequence

A typical write sequence for writing 16 bits to a register is shown in Figure 9. A start bit given by the master, followed by the write address, starts the sequence. The image sensor then gives an acknowledge bit and expects the register address to come first, followed by the 16-bit data. After each 8-bit the image sensor gives an acknowledge bit. All 16 bits must be written before the register is updated. After 16 bits are transferred, the register address is automatically incremented, so that the next 16 bits are written to the next register. The master stops writing by sending a start or stop bit.

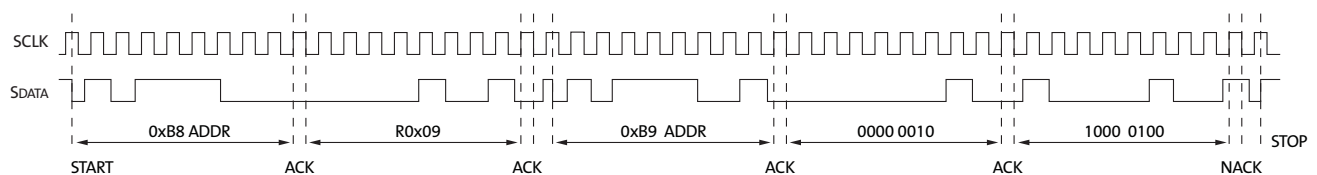
**Figure 9:** Timing Diagram Showing a Write to R0x09 with the Value 0x0284



### 16-Bit Read Sequence

A typical read sequence is shown in Figure 10. First the master has to write the register address, as in a write sequence. Then a start bit and the read address specifies that a read is about to happen from the register. The master then clocks out the register data 8 bits at a time. The master sends an acknowledge bit after each 8-bit transfer. The register address is auto-incremented after every 16 bits is transferred. The data transfer is stopped when the master sends a no-acknowledge bit.

**Figure 10:** Timing Diagram Showing a Read from R0x09; Returned Value 0x0284

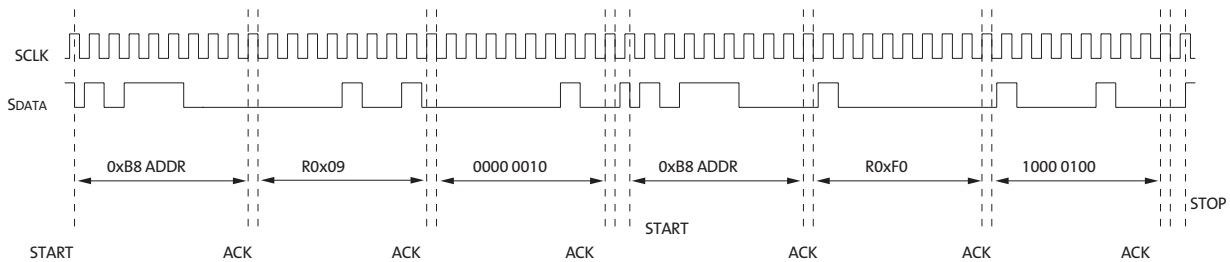




### 8-Bit Write Sequence

To be able to write 1 byte at a time to the register a special register address is added. The 8-bit write is done by first writing the upper 8 bits to the desired register and then writing the lower 8 bits to the Byte-wise Address register (R0xF0). The register is not updated until all 16 bits have been written. It is not possible to just update half of a register. In Figure 11, a typical sequence for 8-bit writing is shown. The second byte is written to the Byte-wise register (R0xF0).

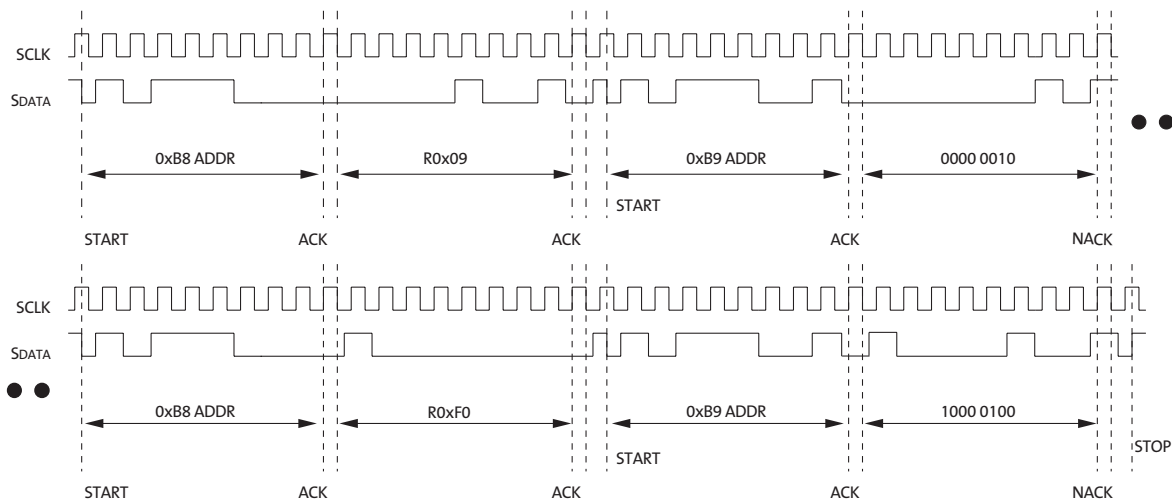
**Figure 11: Timing Diagram Showing a Byte-wise Write to R0x09 with the Value 0x0284**



### 8-Bit Read Sequence

To read one byte at a time the same special register address is used for the lower byte. The upper 8 bits are read from the desired register. By following this with a read from the byte-wise address register (R0xF0) the lower 8 bits are accessed (Figure 12). The master sets the no-acknowledge bits shown.

**Figure 12: Timing Diagram Showing a Byte-wise Read from R0x09; Returned Value 0x0284**





## Register Lock

Included in the MT9V024 is a register lock (R0xFE) feature that can be used as a solution to reduce the probability of an inadvertent noise-triggered two-wire serial interface write to the sensor. All registers, or only the read mode registers—R0x0D and R0x0E, can be locked. It is important to prevent an inadvertent two-wire serial interface write to the read mode registers in automotive applications since this register controls the image orientation and any unintended flip to an image can cause serious results.

At power-up, the register lock defaults to a value of 0xBEEF, which implies that all registers are unlocked and any two-wire serial interface writes to the register gets committed.

### Lock All Registers

If a unique pattern (0xDEAD) to R0xFE is programmed, any subsequent two-wire serial interface writes to registers (except R0xFE) are NOT committed. Alternatively, if the user writes a 0xBEEF to the register lock register, all registers are unlocked and any subsequent two-wire serial interface writes to the register are committed.

### Lock Only Read Mode Registers (R0x0D and R0x0E)

If a unique pattern (0xDEAF) to R0xFE is programmed, any subsequent two-wire serial interface writes to R0x0D or R0x0E are NOT committed. Alternatively, if the user writes a 0xBEEF to register lock register, registers R0x0D and R0x0E are unlocked and any subsequent two-wire serial interface writes to these registers are committed.



## Real-Time Context Switching

In the MT9V024, the user may switch between two full register sets (listed in Table 7) by writing to a context switch change bit in register 0x07. This context switch will change all registers (no shadowing) at the frame start time and have the new values apply to the immediate next exposure and readout time.

**Table 7: Real-Time Context-Switchable Registers**

Register Name	Register Number (Hex) For Context A	Register Number (Hex) for Context B
Column Start	0x01	0xC9
Row Start	0x02	0xCA
Window Height	0x03	0xCB
Window Width	0x04	0xCC
Horizontal Blanking	0x05	0xCD
Vertical Blanking	0x06	0xCE
Coarse Shutter Width 1	0x08	0xCF
Coarse Shutter Width 2	0x09	0xD0
Coarse Shutter Width Control	0x0A	0xD1
Coarse Shutter Width Total	0x0B	0xD2
Fine Shutter Width 1	0xD3	0xD6
Fine Shutter Width 2	0xD4	0xD7
Fine Shutter Width Total	0xD5	0xD8
Read Mode	0x0D [5:0]	0x0E [5:0]
High Dynamic Range enable	0x0F [0]	0x0F [8]
ADC Resolution Control	0x1C [1:0]	0x1C [9:8]
V1 Control – V4 Control	0x31 – 0x34	0x39 – 0x3C
Analog Gain Control	0x35	0x36
Row Noise Correction Control 1	0x70 [1:0]	0x70 [9:8]
Tiled Digital Gain	0x80 [3:0] – 0x98 [3:0]	0x80 [11:8] – 0x98 [11:8]
AEC/AGC Enable	0xAF [1:0]	0xAF [9:8]



## Registers

**Caution** Writing and changing the value of a reserved register (word or bit) puts the device in an unknown state and may damage the device.

**Table 8: Default Register Descriptions**  
1 = always 1; 0 = always 0; d = programmable; ? = read only

Register Number (Hex)	Description	Data Format (Binary)	Default Value (Hex)
0x00	Chip Version	0001 0011 0010 0100 (LSB)	Iter. 1: 0x1324
0x01	Column Start	0000 00dd dddd dddd	0x0001
0x02	Row Start Context A	0000 000d dddd dddd	0x0004
0x03	Window Height Context A	0000 000d dddd dddd	0x01E0
0x04	Window Width Context A	0000 00dd dddd dddd	0x02F0
0x05	Horizontal Blanking Context A	0000 00dd dddd dddd	0x005E
0x06	Vertical Blanking Context A	0ddd dddd dddd dddd	0x002D
0x07	Chip Control	0000 dddd dddd dddd	0x0388
0x08	Coarse Shutter Width 1 Context A	0ddd dddd dddd dddd	0x01BB
0x09	Coarse Shutter Width 2 Context A	0ddd dddd dddd dddd	0x01D9
0x0A	Shutter Width Ctrl Context A	0000 00dd dddd dddd	0x0164
0x0B	Coarse Total Shutter Width Context A	0ddd dddd dddd dddd	0x01E0
0x0C	Reset	0000 0000 0000 00dd	0x0000
0x0D	Read Mode Context A	0000 0011 dddd dddd	0x0300
0x0E	Read Mode Context B	0000 0000 00dd dddd	0x0000
0x0F	Sensor Type, HDR Enable	0000 000d 0000 00dd	0x0100
0x10	Reserved	–	0x0040
0x11	Reserved	–	0x8042
0x12	Reserved	–	0x0022
0x13	Reserved	–	0x2D32
0x14	Reserved	–	0x0E02
0x15	Reserved	–	0x0E32
0x16	Reserved	–	0x2802
0x17	Reserved	–	0x3E38
0x18	Reserved	–	0x3E38
0x19	Reserved	–	0x2802
0x1A	Reserved	–	0x0428
0x1B	LED_OUT Ctrl	0000 0000 0000 00dd	0x0000
0x1C	Companding	0000 00dd 0000 00dd	0x0302
0x1D	Reserved	–	0x0040
0x1E	Reserved	–	0x0000
0x1F	Reserved	–	0x0000
0x20	Reserved	–	0x01C1
0x21	Reserved	–	0x0020
0x22	Reserved	–	0x0020
0x23	Reserved	–	0x0010
0x24	Reserved	–	0x0010
0x25	Reserved	–	0x0020
0x26	Reserved	–	0x0004



**Table 8: Default Register Descriptions (continued)**  
1 = always 1; 0 = always 0; d = programmable; ? = read only

Register Number (Hex)	Description	Data Format (Binary)	Default Value (Hex)
0x27	Reserved	–	0x000C
0x28	Reserved	–	0x0010
0x29	Reserved	–	0x0010
0x2A	Reserved	–	0x0020
0x2B	Reserved	–	0x0004
0x2C	VREF_ADC Control	0000 0000 0000 0ddd	0x0004
0x2D	Reserved	–	0x0004
0x2E	Reserved	–	0x0007
0x2F	Reserved	–	0x0004
0x30	Reserved	–	0x0003
0x31	V1 Context A	0000 0000 000d dddd	0x0027
0x32	V2 Context A	0000 0000 000d dddd	0x001A
0x33	V3 Context A	0000 0000 000d dddd	0x0005
0x34	V4 Context A	0000 0000 000d dddd	0x0003
0x35	Analog Gain Context A	0000 0000 0ddd dddd	0x0010
0x36	Analog Gain Context B	0000 0000 0ddd dddd	0x8010
0x37	Reserved	–	0x0000
0x38	Reserved	–	0x0000
0x39	V1 Control Context B	0000 0000 00dd dddd	0x27
0x3A	V2 Control Context B	0000 0000 00dd dddd	0x26
0x3B	V3 Control Context B	0000 0000 00dd dddd	0x5
0x3C	V4 Control Context B	0000 0000 00dd dddd	0x3
0x40	Reserved	0000 0000 ???? ????	RO
0x42	Frame Dark Average	0000 0000 ???? ????	RO
0x46	Dark Avg Thresholds	dddd dddd dddd dddd	0x231D
0x47	BL Calib Control	1000 0000 ddd0 000d	0x0080
0x48	Black Level Calibration Value	0000 0000 dddd dddd	0x0000
0x4C	BL Calib Step Size	0000 0000 000d dddd	0x0002
0x60	Reserved	0000 0000 0000 0000	0x0000
0x61–0x66	Unused	–	0x0000
0x67	Reserved	–	0x0000
0x68	Reserved	–	RO
0x69	Reserved	–	RO
0x6A	Reserved	–	RO
0x6B	Reserved	–	RO
0x6C	Reserved	–	0x0000
0x70	Row Noise Corr Control	0000 00dd 0000 00dd	0x0000
0x71	Row Noise Constant	0000 00dd dddd dddd	0x002A
0x72	Pixclk, FV, LV Ctrl	0000 0000 000d dddd	0x0000
0x73–0x7E	Unused	–	0x0000
0x7F	Digital Test Pattern	0ddd ddd dddd dddd	0x0000
0x80	Tile Weight/Gain X0_Y0	0000 dddd dddd dddd	0x04F4
0x81	Tile Weight/Gain X1_Y0	0000 dddd dddd dddd	0x04F4
0x82	Tile Weight/Gain X2_Y0	0000 dddd dddd dddd	0x04F4



**Table 8: Default Register Descriptions (continued)**  
1 = always 1; 0 = always 0; d = programmable; ? = read only

Register Number (Hex)	Description	Data Format (Binary)	Default Value (Hex)
0x83	Tile Weight/Gain X3_Y0	0000 dddd dddd dddd	0x04F4
0x84	Tile Weight/Gain X4_Y0	0000 dddd dddd dddd	0x04F4
0x85	Tile Weight/Gain X0_Y1	0000 dddd dddd dddd	0x04F4
0x86	Tile Weight/Gain X1_Y1	0000 dddd dddd dddd	0x04F4
0x87	Tile Weight/Gain X2_Y1	0000 dddd dddd dddd	0x04F4
0x88	Tile Weight/Gain X3_Y1	0000 dddd dddd dddd	0x04F4
0x89	Tile Weight/Gain X4_Y1	0000 dddd dddd dddd	0x04F4
0x8A	Tile Weight/Gain X0_Y2	0000 dddd dddd dddd	0x04F4
0x8B	Tile Weight/Gain X1_Y2	0000 dddd dddd dddd	0x04F4
0x8C	Tile Weight/Gain X2_Y2	0000 dddd dddd dddd	0x04F4
0x8D	Tile Weight/Gain X3_Y2	0000 dddd dddd dddd	0x04F4
0x8E	Tile Weight/Gain X4_Y2	0000 dddd dddd dddd	0x04F4
0x8F	Tile Weight/Gain X0_Y3	0000 dddd dddd dddd	0x04F4
0x90	Tile Weight/Gain X1_Y3	0000 dddd dddd dddd	0x04F4
0x91	Tile Weight/Gain X2_Y3	0000 dddd dddd dddd	0x04F4
0x92	Tile Weight/Gain X3_Y3	0000 dddd dddd dddd	0x04F4
0x93	Tile Weight/Gain X4_Y3	0000 dddd dddd dddd	0x04F4
0x94	Tile Weight/Gain X0_Y4	0000 dddd dddd dddd	0x04F4
0x95	Tile Weight/Gain X1_Y4	0000 dddd dddd dddd	0x04F4
0x96	Tile Weight/Gain X2_Y4	0000 dddddddd dddd	0x04F4
0x97	Tile Weight/Gain X3_Y4	0000 dddd dddd dddd	0x04F4
0x98	Tile Weight/Gain X4_Y4	0000 dddd dddd dddd	0x04F4
0x99	Tile Coord. X 0/5	0000 00dd dddd dddd	0x0000
0x9A	Tile Coord. X 1/5	0000 00dd dddd dddd	0x0096
0x9B	Tile Coord. X 2/5	0000 00dd dddd dddd	0x012C
0x9C	Tile Coord. X 3/5	0000 00dd dddd dddd	0x01C2
0x9D	Tile Coord. X 4/5	0000 00dd dddd dddd	0x0258
0x9E	Tile Coord. X 5/5	0000 00dd dddd dddd	0x02F0
0x9F	Tile Coord. Y 0/5	0000 000d dddd dddd	0x0000
0xA0	Tile Coord. Y 1/5	0000 000d dddd dddd	0x0060
0xA1	Tile Coord. Y 2/5	0000 000d dddd dddd	0x00C0
0xA2	Tile Coord. Y 3/5	0000 000d dddd dddd	0x0120
0xA3	Tile Coord. Y 4/5	0000 000d dddd dddd	0x0180
0xA4	Tile Coord. Y 5/5	0000 000d dddd dddd	0x01E0
0xA5	AEC/AGC Desired Bin	0000 0000 00dd dddd	0x003A
0xA6	AEC Update Frequency	0000 0000 0000 dddd	0x0002
0xA7	Unused	0000 0000 0000 0000	0x0000
0xA8	AEC LPF	0000 0000 0000 00dd	0x0000
0xA9	AGC Update Frequency	0000 0000 0000 dddd	0x0002
0xAA	AGC LPF	0000 0000 0000 00dd	0x0002
0xAB	Max Analog Gain	0000 0000 0ddd dddd	0x0040
0xAC	AEC Minimum Exposure	dddd dddd dddd dddd	0x0001
0xAD	AEC Maximum Exposure	dddd dddd dddd dddd	0x01E0
0xAE	Bin Difference Threshold	0000 0000 dddd dddd	0x0014





**Table 8: Default Register Descriptions (continued)**  
1 = always 1; 0 = always 0; d = programmable; ? = read only

Register Number (Hex)	Description	Data Format (Binary)	Default Value (Hex)
0xAF	AEC/AGC Enable A/B	0000 00dd 0000 00dd	0x0003
0xB0	AEC/AGC Pix Count	dddd dddd dddd dddd	0xABE0
0xB1	LVDS Master Ctrl	0000 0000 0000 dddd	0x0002
0xB2	LVDS Shift Clk Ctrl	0000 0000 000d 0ddd	0x0010
0xB3	LVDS Data Ctrl	0000 0000 000d 0ddd	0x0010
0xB4	Data Stream Latency	0000 0000 0000 00dd	0x0000
0xB5	LVDS Internal Sync	0000 0000 0000 000d	0x0000
0xB6	LVDS Payload Control	0000 0000 0000 000d	0x0000
0xB7	Stereoscop. Error Ctrl	0000 0000 0000 0ddd	0x0000
0xB8	Stereoscop. Error Flag	0000 0000 0000 000?	RO
0xB9	LVDS Data Output	???? ???? ???? ????	RO
0xBA	AGC Gain Output	0000 0000 0??? ????	RO
0xBB	AEC Gain Output	???? ???? ???? ????	RO
0xBC	AGC/AEC Current Bin	0000 0000 00?? ????	RO
0xBD – 0xBE	Reserved	0000 0000 0000 0000	0x0000
0xBF	Interlace Field Blank	0000 000d dddd dddd	0x0016
0xC0	Mon Mode Capture Ctrl	0000 0000 dddd dddd	0x000A
0xC1	Reserved	0000 00?? ???? ????	RO
0xC2	Anti-eclipse Controls	00dd d000 d100 0000	0x0840
0xC3	Reserved	0000 000? ???? ????	0x007F
0xC4	Reserved	0000 0000 ???? ????	0x007F
0xC5	Reserved	0000 0000 ???? ????	0x007F
0xC6	NTSV FV and LV Control	0000 0000 0000 00dd	0x0
0xC7	NTSC Horiz Blank Ctrl	dddd dddd dddd dddd	0x4416
0xC8	NTSC Vert Blank Ctrl	dddd dddd dddd dddd	0x4421
0xC9	Column Start Context B	0000 00dd dddd dddd	0x001
0xCA	Row Start Context B	0000 000d dddd dddd	0x004
0xCB	Window Height Context B	0000 000d dddd dddd	0x1E0
0xCC	Window Width Context B	0000 00dd dddd dddd	0x2F0
0xCD	Horizontal Blanking Context B	0000 00dd dddd dddd	0x5E
0xCE	Vertical Blanking Context B	0ddd dddd dddd dddd	0x2D
0xCF	Coarse SW1 Context B	0ddd dddd dddd dddd	0x1DE
0xD0	Coarse SW2 Context B	0ddd dddd dddd dddd	0x1DF
0xD1	Shutter Width Ctrl Context B	0000 00dd dddd dddd	0x064
0xD2	Coarse Shutter Width Total Context B	0ddd dddd dddd dddd	0x1E0
0xD3	Fine SW1 Context A	0000 00dd dddd dddd	0x0000
0xD4	Fine SW2 Context A	0000 00dd dddd dddd	0x0000
0xD5	Fine Shutter Width Total Context A	0000 0ddd dddd dddd	0x0000
0xD6	Fine SW1 Context B	0000 0ddd dddd dddd	0x0000
0xD7	Fine SW2 Context B	0000 0ddd dddd dddd	0x0000
0xD8	Fine Shutter Width Total Context B	0000 0ddd dddd dddd	0x0000
0xD9	Monitor Mode	0000 0000 0000 000d	0x0000
0xF0	Byte-wise Addr	0000 0000 dddd dddd	0x0000
0xFE	Register Lock	dddd dddd dddd dddd	0xBEEF



## Shadowed Registers

Some sensor settings cannot be changed during frame readout. For example, changing window width R0x04 part way through frame readout results in inconsistent LV behavior. To avoid this, the MT9V024 double-buffers many registers by implementing a “pending” and a “live” version. Two-wire serial interface READs and WRITEs access the pending register. The live register controls the sensor operation. The value in the pending register is transferred to a live register at a fixed point in the frame timing, called “frame-start.” Frame-start is defined as the point at which the first dark row is read out. By default, this occurs four row times before FRAME\_VALID (FV) goes HIGH. To determine which registers or register fields are double-buffered in this way, see the “Shadowed” column in Table 9.

Notation used in the register description table:

- Shadowed  
N = No. The register value is updated and used immediately.  
Y = Yes. The register value is updated at next frame start. Frame start is defined as when the first dark row is read out. By default this is four rows before FV goes HIGH.
- Read/Write  
R = Read-only register/bit.  
W = Read/Write register/bit.

Table 9 provides a detailed description of the registers. Bit fields that are not identified in the table are read only.

**Table 9: Register Descriptions**

Bit	Bit Name	Bit Description	Default in Hex (Dec)	Shadowed	Legal Values (Dec)	Read/Write
0x00/0xFF (0/255) Chip Version						
15:0	Chip Version	Chip version—read-only	0x1324 (4900)			R
0x01 (1) Column Start Context A						
9:0	Column Start	The first column to be read out (not counting dark columns that may be read). To window the image down, set this register to the starting X value. Readable/active columns are 1–752.	001 (1)	Y	1–752	W
0x02 (2) Row Start Context A						
8:0	Row Start	The first row to be read out (not counting any dark rows that may be read). To window the image down, set this register to the starting Y value. Setting a value less than four is not recommended since the dark rows should be read using R0x0D.	004 (4)	N	4–482	W
0x03 (3) Window Height Context A						
8:0	Window Height	Number of rows in the image to be read out (not counting any dark rows or border rows that may be read).	1E0 (480)	Y	1–480	W
0x04 (4) Window Width Context A						
9:0	Window Width	Number of columns in image to be read out (not counting any dark columns or border columns that may be read).	2F0 (752)	N	1–752	W
0x05 (5) Horizontal Blanking Context A						



Table 9: Register Descriptions (continued)

Bit	Bit Name	Bit Description	Default in Hex (Dec)	Shadowed	Legal Values (Dec)	Read/Write
9:0	Horizontal Blanking	Number of blank columns in a row. Minimum horizontal blanking is 61 for normal mode, 71 for column bin 2 mode, and 91 for column bin 4 mode	05E (94)	Y	61–1023	W
0x06 (6) Vertical Blanking Context A						
14:0	Vertical Blank	Number of blank rows in a frame. V-Blank value must meet the following minimums: Linear Mode: V-Blank (min) = (SW_total - SW1 + 7) = SW_total - R0x08 + 7 If manual exposure, then SW_total = R0x0B. If auto-exposure mode then SW_total = R0xAD.  High Dynamic Range Mode: If Auto-Knee Point disabled, then above equations apply. If Auto-Knee Point enabled, then V-Blank (min) = (t2 + t3 + 7).  Notes: 1. Calculate t2 and t3 taking into account Auto-Exposure setting. 2. When Sequential Mode is enabled, this register is ineffective. Vertical blank = exposure + 6 rows.	002D (45)	N	2–32288	W
0x07 (7) Chip Control						
2:0	Scan Mode	0 = Progressive scan. 1 = Not valid. 2 = Two-field Interlaced scan. Even-numbered rows are read first, and followed by odd-numbered rows. 3 = Single-field Interlaced scan. If the start address is an even number, only even-numbered rows are read out; if the start address is an odd number, only odd-numbered rows are read out. Effective image size is decreased by half.	0	Y	0, 2, 3	W
4–3	Sensor Operating Mode	0 = Slave mode. The user is allowed to initiate exposure and readout. 1 = Master mode. Sensor generates its own exposure and readout timing according to simultaneous/sequential mode control bit. 2 = Invalid mode. 3 = Snapshot mode. The user triggers the start of frame by providing a pulse at EXPOSURE pin.	1	Y	0, 1, 3	W
5	Stereoscopy Mode	0 = Stereoscopy disabled. Sensor is stand-alone and the PLL generates a 320 MHz (x12) clock. Typical maximum cable length is 8 meters. 1 = Stereoscopy enabled. The PLL generates a 540 MHz (x18) clock. Typical maximum cable length is 5 meters.	0	Y	0, 1	W
6	Stereoscopic Master/Slave mode	0 = Stereoscopic master. 1 = Stereoscopic slave. Stereoscopy mode should be enabled when using this bit.	0	Y	0, 1	W



Table 9: Register Descriptions (continued)

Bit	Bit Name	Bit Description	Default in Hex (Dec)	Shadowed	Legal Values (Dec)	Read/Write
7	Parallel Output Enable	0 = Disables parallel output, LV and FV. DOUT[9:0], FRAME_VALID, and LINE_VALID are forced to logic "0" in sensor digital core. It does not control pads. 1 = Enables parallel output.	1	Y	0,1	W
8	Simultaneous/Sequential Mode	0 = Sequential mode. Pixel and column readout take place only after exposure is complete. 1 = Simultaneous mode. Pixel and column readout take place in conjunction with exposure.	1	Y	0,1	W
9	Defective Pixel Correction Enable	0 = Disable Defective Pixel Correction feature. 1 = Enable Defective Pixel Correction feature.	1	Y	0, 1	W
15	Context A/B Select	0 = Context A registers are used. 1 = Context B registers are used.	0	Y	0, 1	W
0x08 (8) Coarse Shutter Width 1 Context A						
14:0	Coarse Shutter Width 1	The row number in which the first knee occurs. This may be used when high dynamic range is enabled (R0x0F[0] = 1) and exposure knee point auto adjust is disabled (R0x0A[8] = 0). This register is not shadowed, but any change made does not take effect until the following new frame. This register's minimum value is 2, for either linear or HDR modes. Note: t1 = Shutter width 1; t2 = Shutter width 2 - Shutter width 1; t3 = total integration - Shutter width 2.	1BB (443)	N	0–32765	W
0x09 (9) Coarse Shutter Width 2 Context A						
14:0	Course Shutter Width 2	The row number in which the second knee occurs. This may be used only when high dynamic range is enabled and exposure knee point auto adjust control bit is disabled. This register is not shadowed, but any change made does not take effect until the following new frame. Note: t1 = Shutter width 1; t2 = Shutter width 2 – Shutter 1; t3 = Total integration – Shutter width 2.	1D9 (473)	N	0–32765	W
0x0A (10) Shutter Width Control Context A						
3:0	T2 Ratio	When Exposure Knee Point Auto Adjust is enabled, then one-half to the power of this value indicates the ratio of duration time t2, when saturation control gate is adjusted to level V2, to total coarse integration. This register is not shadowed, but any change made does not take effect until the following new frame. $T2 = \text{Total coarse integration} \times (\frac{1}{2})^{t2\_ratio}$ .	4	N	0–15	W



Table 9: Register Descriptions (continued)

Bit	Bit Name	Bit Description	Default in Hex (Dec)	Shadowed	Legal Values (Dec)	Read/Write
7:4	T3 Ratio	When Exposure Knee Point Auto Adjust is enabled, then one-half to the power of this value indicates the ratio of duration time $t_3$ , when saturation control gate is adjusted to level V3, to total coarse integration. This register is not shadowed, but any change made does not take effect until the following new frame. $t_3 = \text{Total integration} \times (\frac{1}{2})^{t_3\text{-ratio}}$ Note: $t_3 = \text{Total integration} - t_2 - t_1$ .	6	N	0–15	W
8	Exposure Knee Point Auto Adjust Enable	0 = Auto adjust disabled. 1 = Auto adjust enabled.	1	N	0,1	W
9	Single Knee Enable	0 = Single knee disabled. 1 = Single knee enabled.	0	N	0,1	W
0x0B (11) Coarse Shutter Width Total Context A						
14:0	Coarse Shutter Width Total	Total integration time in number of rows. This value is used only when AEC is disabled only (bit 0 of R0xAF). This register is not shadowed, but any change made does not take effect until the following new frame.	1E0 (480)	N	0–32765	W
0x0C (12) Reset						
0	Soft Reset	Setting this bit will cause the sensor to abandon the current frame by resetting all digital logic except two-wire serial interface configuration. This is a self-resetting register bit and should always read "0." (This bit de-asserts internal active LOW reset signal for 15 clock cycles.)	0	N	0, 1	W
1	Auto Block Soft Reset	Setting this bit causes the sensor to reset the automatic gain and exposure control logic. This is a self-resetting register bit and should always read "0." (This bit de-asserts internal active LOW reset signal for 15 clock cycles.)	0	Y	0, 1	W
0x0D (13) Read Mode Context A						
1:0	Row Bin	0 = Normal operation. 1 = Row bin 2. Two pixel rows are read per row output. Image size is effectively reduced by a factor of 2 vertically while data rate and pixel clock are not affected. Resulting frame rate is increased by 2. 2 = Row bin 4. Four pixel rows are read per row output. Image size is effectively reduced by a factor of 4 vertically while data rate and pixel clock are not affected. Resulting frame rate is increased by 4. 3 = Not valid.	0	Y	0, 1, 2	W



Table 9: Register Descriptions (continued)

Bit	Bit Name	Bit Description	Default in Hex (Dec)	Shadowed	Legal Values (Dec)	Read/Write
3:2	Column Bin	0 = Normal operation. 1 = Column bin 2. When set, image size is reduced by a factor of 2 horizontally. Frame rate is not affected but data rate and pixel clock are reduced by one-half that of master clock. 2 = Column bin 4. When set, image size is reduced by a factor of 4 horizontally. Frame rate is not affected but data rate and pixel clock are reduced by one-fourth that of master clock. 3 = Not valid.	0	Y	0, 1, 2	W
4	Row Flip	Read out rows from bottom to top (upside down). When set, row readout starts from row (Row Start + Window Height) and continues down to (Row Start + 1). When clear, readout starts at Row Start and continues to (Row Start + Window Height - 1). This ensures that the starting color is maintained. This one pixel adjustment is always performed, for monochrome or color versions.	0	Y	0, 1	W
5	Column Flip	Read out columns from right to left (mirrored). When set, column readout starts from column (Col Start + Window Width) and continues down to (Col Start + 1). When clear, readout starts at Col Start and continues to (Col Start + Window Width - 1). This ensures that the starting color is maintained. This one pixel adjustment is always performed, for monochrome or color versions.	0	Y	0, 1	W
6	Show Dark Rows	When set, three dark rows are output before the active window. Frame valid is thus asserted earlier than normal. This has no effect on integration time or frame rate. Whether the dark rows are shown in the image or not the definition frame start is before the dark rows are read out.	0	Y	0, 1	W
7	Show Dark Columns	When set, 36 dark columns are output before the active pixels in a line. Line valid is thus asserted earlier than normal, and the horizontal blank time is shortened by 36 pixel clocks.	0	Y	0, 1	W
9:8	Reserved	Reserved.	3		3	
0x0E (14) Read Mode Context B						
1:0	Row Bin	0 = Normal Operation 1 = Row bin 2. Two pixel rows are read per row output. Image size is effectively reduced by a factor of 2 vertically while data rate and pixel clock are not affected. Resulting frame rate is increased by 2. 2 = Row bin 4. Four pixel rows are read per row output. Image size is effectively reduced by a factor of 4 vertically w Resulting frame rate is increased by 4. 3 = Invalid	0	Y	0, 1, 2	W



Table 9: Register Descriptions (continued)

Bit	Bit Name	Bit Description	Default in Hex (Dec)	Shadowed	Legal Values (Dec)	Read/Write
0x0F (15) Sensor Type Control						
0	High Dynamic Range Context A	0 = Linear operation. If Linear mode is selected, then Exposure Knee Point Auto Adjust must also be enabled (R0x0A[8] = 1). 1 = High Dynamic Range. Voltage and shutter width must be correctly set for saturation control to operate.	0	N	0, 1	W
1	Color/Mono Sensor Control	This bit controls some color-specific logic in Black Level Correction and Defective Pixel Correction. 0 = Monochrome 1 = Color It should generally be left at "0" for all part types. It is not required to be set for color sensors to operate properly. When set, it applies an unequal offset to the color planes. For most applications on color parts the bit is best left cleared (monochrome), especially for machine vision applications where predictable image offsets are required. For Black Level Calibration (BLC), when this bit is set, the sensor uses black level correction values from one green plane, which are applied to all colors. Since this bit applies offsets to the color plane, BLC results may be affected. For Defective Pixel Correction (DPC), this bit must be set for the DPC algorithm to calculate replacement pixels based on color plane, otherwise the DPC algorithm will calculate replacement pixels based on nearest-neighbor rather than nearest color-neighbor.	0	Y	0, 1	W
8	High Dynamic Range Context B	0 = Linear operation. If Linear mode is selected, then Exposure Knee Point Auto Adjust must also be enabled (R0xD1[8] = 1). 1 = High Dynamic Range. Voltage and shutter width must be correctly set for saturation control to operate.	1	N	0, 1	W
0x1B (27) LED_OUT Control						
0	Disable LED_OUT	Disable LED_OUT output. When this bit is cleared, the output pin LED_OUT is pulsed HIGH when the sensor is undergoing exposure. When this bit is enabled: If enabled (set to 1), and Invert LED_OUT is disabled, the output pin LED_OUT is held in logic LOW state. If enabled and Invert LED_OUT is enabled, output pin LED_OUT is held in a logic HIGH state.	0	Y	0, 1	W
1	Invert LED_OUT	Inverts polarity of LED_OUT output. When this bit is set, the output pin LED_OUT is pulsed LOW when the sensor is undergoing exposure.	0	Y	0, 1	W
0x1C (28) ADC Companding Mode						
1:0	ADC Mode Context A	0 = Invalid. 1 = Invalid. 2 = 10-bit linear. 3 = 12-to-10-bit companding.	2	N	2, 3	W



**Table 9: Register Descriptions (continued)**

Bit	Bit Name	Bit Description	Default in Hex (Dec)	Shadowed	Legal Values (Dec)	Read/Write
9:8	ADC Mode Context B	0 = Invalid. 1 = Invalid. 2 = 10-bit linear. 3 = 12-to10-bit companding.	3	N	2,3	W
0x2C (44) – 0x3C (60) Analog Controls Note: These registers are not shadowed, but any change made does not take effect until the following new frame.						
0x2C (44) VREF_ADC Control						
2:0	VREF_ADC Voltage Level	0 = VREF_ADC = 1.0V. 1 = VREF_ADC = 1.1V. 2 = VREF_ADC = 1.2V. 3 = VREF_ADC = 1.3V. 4 = VREF_ADC = 1.4V.(Note: Effective ADC reference voltage is 1.0V.) 5 = VREF_ADC = 1.5V. 6 = VREF_ADC = 1.6V. 7 = VREF_ADC = 2.1V. Range: 1.0–2.1V; Default: 1.4V  Note: This register is not shadowed, but any change made does not take effect until the following new frame.	4	N	0–7	W
0x31 (49) V1 Control Context A						
5:0	V1 voltage level	For bits (5:0) = 0 to 5, $V\_step = bits(5:0) * 200mV + 0.2V$ . Range: 0.2 - 1.2V  For bits (5:0) = 6 to 63 $V\_step = bits(5:0) * 23.5mV + 1.62V$ Range: 1.76-3.1V Note: Equation and range are determined with the assumption that VAA = 3.3V. They may vary with actual VAA voltage. Default: 2.54V Usage: Vstep1 HDR voltage	27 (39)	N	0–63	W
0x32 (50) V2 Control Context A						
5:0	V2 voltage level	For bits (5:0) = 0 to 5, $V\_step = bits(5:0) * 200mV + 0.2V$ . Range: 0.2 - 1.2V  For bits (5:0) = 6 to 63 $V\_step = bits(5:0) * 23.5mV + 1.62V$ Range: 1.76-3.1V Note: equation and range are determined with the assumption that VAA = 3.3V. They may vary with actual VAA voltage. Default: 2.23V Usage: Vstep2 HDR voltage	1A (26)	N	0–63	W





Table 9: Register Descriptions (continued)

Bit	Bit Name	Bit Description	Default in Hex (Dec)	Shadowed	Legal Values (Dec)	Read/Write
0x33 (51) V3 Control Context A						
5:0	V3 voltage level	For bits (5:0) = 0 to 5, $V\_step = \text{bits (5:0)} * 200\text{mV} + 0.2\text{V}$ . Range: 0.2 - 1.2V  For bits (5:0) = 6 to 63 $V\_step = \text{bits (5:0)} * 23.5\text{mV} + 1.62\text{V}$ Range: 1.76-3.1V Note: equation and range are determined with the assumption that $V_{AA} = 3.3\text{V}$ . They may vary with actual $V_{AA}$ voltage. Default: 1.2V Usage: Vstep3 HDR voltage.	05 (5)	N	0–63	W
0x34 (52) V4 Control Context A						
5:0	V4 voltage level	For bits (5:0) = 0 to 5, $V\_step = \text{bits (5:0)} * 200\text{mV} + 0.2\text{V}$ . Range: 0.2 - 1.2V  For bits (5:0) = 6 to 63 $V\_step = \text{bits (5:0)} * 23.5\text{mV} + 1.62\text{V}$ Range: 1.76-3.1V Note: equation and range are determined with the assumption that $V_{AA} = 3.3\text{V}$ . They may vary with actual $V_{AA}$ voltage. Default: 0.8V Usage: Vstep HDR parking voltage, also provides anti-blooming when Vstep is disabled.	03 (3)	N	0–63	W
0x35 (53) Analog Gain Context A						
6:0	Global Analog Gain	Analog gain = bits (6:0) x 0.0625 Range: 16 dec - 64dec for 1X-4X respectively  Column amplifier common gain. Note: No exception detection is installed, user needs to be cautious when programming.	10 (16)	N	16–64	W
15	Global Analog Gain Attenuation	When this bit is set, analog gain will be forced to 0.75X.	0	N	0, 1	W
0x36 (54) Analog Gain Context B						
6:0	Global Analog Gain	Analog gain = bits (6:0) x 0.0625 Range: 16 dec -64dec for 1X-4X respectively  Column amplifier common gain. Note: No exception detection is installed, user needs to be cautious when programming.	10 (16)	N	16–64	W
15	Global Analog Gain Attenuation	When this bit is set, analog gain will be forced to 0.75X.	1	N	0, 1	W



Table 9: Register Descriptions (continued)

Bit	Bit Name	Bit Description	Default in Hex (Dec)	Shadowed	Legal Values (Dec)	Read/Write
0x39 (57) V1 Control Context B						
5:0	V1 Voltage Level	<p>For bits (5:0) = 0 to 5,  <math>V\_step = bits(5:0) * 200mV + 0.2V</math>.            Range: 0.2 - 1.2V</p> <p>For bits (5:0) = 6 to 63  <math>V\_step = bits(5:0) * 23.5mV + 1.62V</math>            Range: 1.76-3.1V            Note: equation and range are determined with the assumption that <math>V_{AA} = 3.3V</math>. They may vary with actual <math>V_{AA}</math> voltage.            Default: 2.54V            Usage: Vstep 1 HDR voltage</p>	27 (39)	N	0-63	W
0x3A (58) V2 Control Context B						
5:0	V2 Voltage Level	<p>For bits (5:0) = 0 to 5,  <math>V\_step = bits(5:0) * 200mV + 0.2V</math>.            Range: 0.2 - 1.2V</p> <p>For bits (5:0) = 6 to 63  <math>V\_step = bits(5:0) * 23.5mV + 1.62V</math>            Range: 1.76-3.1V            Note: Equation and range are determined with the assumption that <math>V_{AA} = 3.3V</math>. They may vary with actual <math>V_{AA}</math> voltage.            Default: 2.51V            Usage: Vstep2 HDR voltage</p>	36 (38)	N	0-63	W
0x3B (59) V3 Control Context B						
5:0	V3 Voltage Level	<p>For bits (5:0) = 0 to 5,  <math>V\_step = bits(5:0) * 200mV + 0.2V</math>.            Range: 0.2 - 1.2V</p> <p>For bits (5:0) = 6 to 63  <math>V\_step = bits(5:0) * 23.5mV + 1.62V</math>            Range: 1.76-3.1V            Note: Equation and range are determined with the assumption that <math>V_{AA} = 3.3V</math>. They may vary with actual <math>V_{AA}</math> voltage.            Default: 1.2V            Usage: Vstep3 HDR voltage</p>	05 (5)	N	0-63	W
0x3C (60) V4 Control Context B						



Table 9: Register Descriptions (continued)

Bit	Bit Name	Bit Description	Default in Hex (Dec)	Shadowed	Legal Values (Dec)	Read/Write
5:0	V4 Voltage Level	For bits (5:0) = 0 to 5, V_step = bits (5:0) * 200mV + 0.2V. Range: 0.2 - 1.2V For bits (5:0) = 6 to 63 V_step = bits (5:0) * 23.5mV + 1.62V Range: 1.76-3.1V Note: Equation and range are determined with the assumption that VAA = 3.3V. They may vary with actual VAA voltage. Default: 0.8V Usage: Vstep HDR parking voltage, also provides anti-blooming when Vstep is disabled.	03 (3)	N	0–63	W
0x42 (66) Frame Dark Average						
7:0	Frame Dark Average	The value read is the frame averaged black level, that is, used in the black level algorithm calculations.	0			R
0x46 (70) Dark Average Thresholds						
7:0	Lower threshold	Lower threshold for targeted black level in ADC LSBs.	1D (29)	N	0–255	W
15:8	Upper threshold	Upper threshold for targeted black level in ADC LSBs.	23 (35)	N	0–255	W
0x47 (71) Black Level Calibration Control						
0	Manual Override	Manual override of black level correction. 1 = Override automatic black level correction with programmed values. (R0x48). 0 = Normal operation (default).	0	N	0, 1	W
7:5	Frames to average over	Two to the power of this value decide how many frames to average over when the black level algorithm is in the averaging mode. In this mode the running frame average is calculated from the following formula: Running frame ave = Old running frame ave - (old running frame ave)/2n + (new frame ave)/ 2n.	4	N	0–7	W
0x48 (72) Black Level Calibration Value						
7:0	Black Level Calibration Value	Analog calibration offset: Negative numbers are represented with two's complement, which is shown in the following formula: Sign = bit 7 (0 is positive, 1 is negative). If positive offset value: Magnitude = bit 6:0. If negative offset value: Magnitude = not (bit 6:0) + 1. During two-wire serial interface read, this register returns the user-programmed value when manual override is enabled (R0x47 bit 0); otherwise, this register returns the result obtained from the calibration algorithm.	–	N	–127 to 127	RW
0x4C (76) Black Level Calibration Value Step Size						
4:0	Step Size of Calibration Value	This is the size calibration value may change (positively or negatively) from frame to frame. Note: 1 calib LSB = ½ ADC LSB, assuming analog gain = 1.	02	N	0–31	W



Table 9: Register Descriptions (continued)

Bit	Bit Name	Bit Description	Default in Hex (Dec)	Shadowed	Legal Values (Dec)	Read/Write
<b>0x70 (112) Row Noise Correction Control</b>						
0	Enable Noise Correction Context A	0 = Normal operation 1 = Enable row noise cancellation algorithm. When this bit is set, on a per row basis, the dark average will be subtracted from each pixel in the row, and then a constant (Reg 0x71) will be added.	0	N	0, 1	W
1	Use black level average Context A	0 = Use the average value of the dark columns read out in each row as dark average. 1 = Use black level frame average from the dark rows in the row noise correction algorithm for low gains. Note that this frame average was taken before the last adjustment of the offset DAC for that frame, so it might be slightly off.	0	N	0, 1	W
8	Enable noise correction Context B	0 = Normal operation 1 = Enable row noise cancellation algorithm. When this bit is set, on a per row basis, the dark average will be subtracted from each pixel in the row, and then a constant (Reg 0x71) will be added.	0	N	0, 1	W
9	Use black level average Context B	0 = Use the average value of the dark columns read out in each row as dark average. 1 = Use black level frame average from the dark rows in the row noise correction algorithm for low gains. Note that this frame average was taken before the last adjustment of the offset DAC for that frame, so it might be slightly off.	0	N	0, 1	W
<b>0x71 (113) Row Noise Constant</b>						
9:0	Row noise constant	Constant used in the row noise cancellation algorithm. It should be set to the dark level targeted by the black level algorithm plus the noise expected between the averaged values of dark columns. At default the constant is set to 42 LSB.	2A (42)	Y	0–1023	W
<b>0x72 (114) Pixel Clock, FRAME and LINE VALID Control</b>						
0	Invert LINE VALID	Invert LINE_VALID. When set, LINE_VALID will be reset to logic "0" when PDOUT is valid.	0	Y	0, 1	W
1	Invert Frame Valid	Invert FRAME_VALID. When set, FRAME_VALID is reset to logic "0" when frame is valid.	0	Y	0, 1	W
2	XOR Line Valid	1 = LINE_VALID = "Continuous" LINE_VALID XOR FRAME_VALID 0 = LINE_VALID determined by bit 3. Ineffective if Continuous Line Valid is set.	0	Y	0, 1	W
3	Continuous Line Valid	1 = "Continuous" LINE_VALID (continue producing LINE_VALID during vertical blank). 0 = Normal LINE_VALID (default, no LINE_VALID during vertical blank).	0	Y	0, 1	W
4	Invert Pixel Clock	Invert pixel clock. When set, LINE_VALID, FRAME_VALID, and PDOUT will be set up to the rising edge of pixel clock, PIXCLK. When clear, they are set up to the falling edge of PIXCLK.	0	Y	0, 1	W



Table 9: Register Descriptions (continued)

Bit	Bit Name	Bit Description	Default in Hex (Dec)	Shadowed	Legal Values (Dec)	Read/Write
<b>0x7F (127) Digital Test Pattern</b>						
9:0	Two-wire Serial Interface Test Data	The 10-bit test data in this register is used in place of the data from the sensor. The data is inserted at the beginning of the digital signal processing. Both test enable (bit 13) and use two-wire serial interface (bit 10) must be set.	000	N	0–1023	W
10	Use Two-wire Serial Interface Test Data	0 = Use Gray Shade Test Pattern as test data. 1 = Use Two-wire Serial Interface Test Data (bits 9:0) as test data.	0	N	0, 1	W
12:11	Gray Shade Test Pattern	0 = None. 1 = Vertical Shades. 2 = Horizontal Shades. 3 = Diagonal Shade. When bits (12:11) $\neq$ 0, the MT9V024 generates a gray shaded test pattern to be used as digital test data. Ineffective when Use Two-wire Serial Interface Test Data (bit 10) is set.	0	N	0–3	W
13	Test Enable	Enable the use of test data/gray-shaded test pattern in the signal chain. The data will be inserted instead of data from the ADCs.  When using this mode, disable Row Noise Correction (Reg0x70 bit 0 and bit 8). If Row Noise Correction is enabled, the row-wise correction algorithm will process the test data values and the result will not be accurate.	0	Y	0, 1	W
14	Flip Two-Wire Serial Interface Test Data	Use only when bit 10 is set. When set, the Two-Wire Test Data (bits 9:0) will be used in place of the data from ADC/memory on odd columns, while complement of the same data will be used on even columns.	0	N	0, 1	W
<b>0x80 (128) - 0x98 (152) Tiled Digital Gain</b>						
3:0	Tile Gain Context A	Tile Digital Gain = Bits (3:0) * 0.25  See “Digital Gain” on page 59 for additional information.	4 (4)	Y	1–15	W
7:4	Sample Weight	To indicate the weight of individual tile used in the automatic gain/exposure control algorithm  See “Automatic Gain Control and Automatic Exposure Control” on page 62 for additional information.	F (15)	Y	1–15	W
11:8	Tile Gain Context B	Tile Digital Gain = Bits (3:0) * 0.25  See “Digital Gain” on page 59 for additional information.	4 (4)	Y	1–15	W
See “Digital Gain” on page 59, for 0x99 (153) – 0xA4 (164) detailed descriptions.						
<b>0x99 (153) Digital Tile Coordinate 1 - X-direction</b>						
9:0	X <sub>0/5</sub>	The starting x-coordinate of digital tiles X0_*	000 (0)	N	0–752	W
<b>0x9A (154) Digital Tile Coordinate 2 - X-direction</b>						



Table 9: Register Descriptions (continued)

Bit	Bit Name	Bit Description	Default in Hex (Dec)	Shadowed	Legal Values (Dec)	Read/Write
9:0	X <sub>1/5</sub>	The starting x-coordinate of digital tiles X1_*.	096 (150)	N	0–752	W
0x9B (155) Digital Tile Coordinate 3 - X-direction						
9:0	X <sub>2/5</sub>	The starting x-coordinate of digital tiles X2_*.	12C (300)	N	0–752	W
0x9C (156) Digital Tile Coordinate 4 - X-direction						
9:0	X <sub>3/5</sub>	The starting x-coordinate of digital tiles X3_*.	1C2 (450)	N	0–752	W
0x9D (157) Digital Tile Coordinate 5 - X-direction						
9:0	X <sub>4/5</sub>	The starting x-coordinate of digital tiles X4_*.	258 (600)	N	0–752	W
0x9E (158) Digital Tile Coordinate 6 - X-direction						
9:0	X <sub>5/5</sub>	The ending x-coordinate of digital tiles X4_*.	2F0 (752)	N	0–752	W
0x9F (159) Digital Tile Coordinate 1 - Y-direction						
8:0	Y <sub>0/5</sub>	The starting y-coordinate of digital tiles *_Y0.	000 (0)	N	0–480	W
0xA0 (160) Digital Tile Coordinate 2 - Y-direction						
8:0	Y <sub>1/5</sub>	The starting y-coordinate of digital tiles *_Y1.	060 (96)	N	0–480	W
0xA1 (161) Digital Tile Coordinate 3 - Y-direction						
8:0	Y <sub>2/5</sub>	The starting y-coordinate of digital tiles *_Y2.	0C0 (192)	N	0–480	W
0xA2 (162) Digital Tile Coordinate 4 - Y-direction						
8:0	Y <sub>3/5</sub>	The starting y-coordinate of digital tiles *_Y3.	120 (288)	N	0–480	W
0xA3 (163) Digital Tile Coordinate 5 - Y-direction						
8:0	Y <sub>4/5</sub>	The starting y-coordinate of digital tiles *_Y4.	180 (384)	N	0–480	W
0xA4 (164) Digital Tile Coordinate 6 - Y-direction						
8:0	Y <sub>5/5</sub>	The ending y-coordinate of digital tiles *_Y4.	1E0 (480)	N	0–480	W
0xA5 (165) AEC/AGC Desired Bin						
5:0	Desired Bin	User-defined “desired bin” that gives a measure of how bright the image is intended.	3A (58)	Y	1–64	W
0xA6 (166) AEC Update Frequency						
3:0	Exp Skip Frame	The number of frames that the AEC must skip before updating the exposure register (R0xBB).	2	Y	0–15	W



Table 9: Register Descriptions (continued)

Bit	Bit Name	Bit Description	Default in Hex (Dec)	Shadowed	Legal Values (Dec)	Read/Write
<b>0xA8 (168) AEC Low Pass Filter</b>						
1:0	Exp LPF	<p>This value plays in role in determining the increment/decrement size of exposure value from frame to frame. If current bin <math>\neq 0</math> (Reg0xBC),</p> <p>When Exp LPF = 0: Actual new exposure = Calculated new exposure.</p> <p>When Exp LPF = 1: if <math> (Calculated. new exp - current exp)  &gt; (current exp / 4)</math>, Actual new exposure = Calculated new exposure, otherwise Actual new exposure = Current exp +/- (calc new exp/2)</p> <p>When Exp LPF = 2: if <math> (Calculated new exp - current exp)  &gt; (current exp / 4)</math>, Actual new exposure = Calc. new exposure, otherwise Actual new exposure = Current exp +/- (calc new exp/4)</p>	0	Y	0–2	W
<b>0xA9 (169) AGC Output Update Frequency</b>						
3:0	Gain Skip Frame	The number of frames that the AGC must skip before updating the gain register (R0xBA).	2	Y	0–15	W
<b>0xAA (170) AGC Low Pass Filter</b>						
1:0	Gain LPF	<p>This value plays a role in determining the increment/decrement size of gain value from frame to frame. If current bin (R0xBC) <math>\neq 0</math></p> <p>When Gain LPF = 0: Actual new gain = Calculated new gain</p> <p>When Exp LPF = 1: if <math> (Calculated new gain - current gain)  &gt; (current gain / 4)</math>, Actual new gain = Calculated new gain, otherwise Actual new gain = Current gain <math>\pm</math> (calculated new gain / 2)</p> <p>When Exp LPF = 2: if <math> (Calculated new gain - current gain)  &gt; (current gain / 4)</math>, Actual new gain = Calculated new gain, otherwise Actual new gain = Current gain <math>\pm</math> (calculated new gain / 4).</p>	2	Y	0–2	W



Table 9: Register Descriptions (continued)

Bit	Bit Name	Bit Description	Default in Hex (Dec)	Shadowed	Legal Values (Dec)	Read/Write
<b>0xAB (171) Maximum Analog Gain</b>						
6:0	Maximum Analog Gain	This register is used by the automatic gain control (AGC) as the upper threshold of gain. This ensures the new calibrated gain value will not exceed that which MT9V024 supports. Range: 16 dec -64dec for 1X-4X respectively Note: No exception detection is installed, user needs to be cautious when programming.	40 (64)	N	16–64	W
<b>0xAC (172) Minimum Coarse Shutter Width</b>						
15:0	Minimum Coarse Shutter Width Total	This register is used by the automatic exposure control (AEC) as the lower threshold of exposure. This ensures the new calibrated integration value will not exceed that which MT9V024 supports.	1	N	1–32765	W
<b>0xAD (173) Maximum Coarse Shutter Width</b>						
15:0	Maximum Coarse Shutter Width Total	This register is used by the automatic exposure control (AEC) as the upper threshold of exposure. This ensures the new calibrated integration value will not exceed that which MT9V024 supports.	01E0 (480)	N	1–32765	W
<b>0xAE (174) AGC/AEC Bin Difference Threshold</b>						
7:0	Bin Difference Threshold	This register is used by the AEC if exposure reaches the Minimum Coarse Shutter Width value (Reg0xAC). Then if the difference between desired bin (Reg0xA5) and current bin (Reg0xBC) is larger than the threshold, the exposure will be increased.	14 (20)	Y	0–63	W
<b>0xAF (175) AGC/AEC Enable</b>						
0	AEC Enable Context A	0 = Disables Automatic Exposure Control. 1 = Enables Automatic Exposure Control.	1	Y	0, 1	W
1	AGC Enable Context A	0 = Disables Automatic Gain Control. 1 = Enables Automatic Gain Control.	1	Y	0, 1	W
8	AEC Enable Context B	0 = Disables Automatic Exposure Control. 1 = Enables Automatic Exposure Control.	0	Y	0, 1	W
9	AGC Enable Context B	0 = Disables Automatic Gain Control. 1 = Enables Control.	0	Y	0, 1	W
<b>0xB0 (176) AGC/AEC Pixel Count</b>						
15:0	Pixel Count	The number of pixel used for the AEC/AGC histogram.	ABE0 (44,000)	Y	0–65535	W
<b>0xB1 (177) LVDS Master Control</b>						
0	PLL Bypass	0 = Internal shift-CLK is driven by PLL. 1 = Internal shift-CLK is sourced from the LVDS_BYPASS_CLK.	0	Y	0, 1	W
1	LVDS Power-down	0 = Normal operation. 1 = Powers down LVDS block.	1	Y	0, 1	W
2	PLL Test Mode	0 = Normal operation. 1 = The PLL output frequency is equal to the system clock frequency (26.6 MHz).	0	Y	0, 1	W
3	LVDS Test Mode	0 = Normal operation. 1 = The SER_DATAOUT_P drives a square wave in both stereo and stand-alone modes). In stereo mode, ensure that SER_DATAIN_P is logic "0."	0	Y	0, 1	W





Table 9: Register Descriptions (continued)

Bit	Bit Name	Bit Description	Default in Hex (Dec)	Shadowed	Legal Values (Dec)	Read/Write
<b>0xB2 (178) LVDS Shift Clock Control</b>						
2:0	Shift-clk Delay Element Select	The amount of shift-CLK delay that minimizes inter-sensor skew.	0	Y	0–7	W
4	LVDS Clock Output Enable	When this bit is set, the LVDS Clock (SHFT_CLKOUT) pins are disabled. Has no effect on SER_DATAOUT pins.	1	Y	0, 1	W
<b>0xB3 (179) LVDS Data Control</b>						
2:0	Data Delay Element Select	The amount of data delay that minimizes inter-sensor skew.	0	Y	0–7	W
4	LVDS Data Input Enable	When this bit is set, the LVDS Data Receiver (SER_DATAIN pins) is disabled. If this bit is changed, it is mandatory that a soft reset (R0x0C) is then issued for proper operation.	1	Y	0, 1	W
<b>0xB4 (180) LVDS Latency</b>						
1:0	Stream Latency Select	The amount of delay so that the two streams are in sync.	0	Y	0–3	W
<b>0xB5 (181) LVDS Internal Sync</b>						
0	LVDS Internal Sync Enable	When this bit is set, the MT9V024 generates sync pattern (data with all zeros except start bit) on LVDS_SER_DATA_OUT.	0	Y	0, 1	W
<b>0xB6 (182) LVDS Payload Control</b>						
0	Use 10-bit Pixel Enable	When this bit is set, all 10 bits will contain pixel (with embedded controls) in standalone mode. If clear, payload will be 8 bits of pixel with 2 bits of controls.	0	Y	0, 1	W
<b>0xB7 (183) Stereoscopic Error Control</b>						
0	Enable Stereo Error Detect	Set this bit to enable stereo error detect mechanism.	0	Y	0, 1	W
1	Enable Stick Stereo Error Flag	When this bit is set, the stereo error flag remains asserted once an error is detected unless clear stereo error flag (bit 2) is set.	0	Y	0, 1	W
2	Clear Stereo Error Flag	Set this bit to clear the stereoscopic error flag (R0xB8 returns to logic 0).	0	Y	0, 1	W
<b>0xB8 (184) Stereoscopic Error Flag</b>						
0	Stereoscopic Error Flag	Stereoscopic error status flag. It is also directly connected to the ERROR output pin.				R
<b>0xB9 (185) LVDS Data Output</b>						
15:0	Combo Reg	This 16-bit value contains both 8-bit pixel values from both stereoscopic master and slave sensors. It can be used in diagnosis to determine how well in sync the two sensors are. Captures the state when master sensor has issued a reserved byte and slave has not. Note: This register should be read from the stereoscopic master sensor only.				R
<b>0xBA (186) AGC Gain Output</b>						
6:0	AGC Gain	Status register to report the current gain value obtained from the AGC algorithm.	10			R
<b>0xBB (187) AEC Exposure Output</b>						
15:0	AEC Exposure	Status register to report the current exposure value obtained from the AEC algorithm.	00C8 (200)			R



Table 9: Register Descriptions (continued)

Bit	Bit Name	Bit Description	Default in Hex (Dec)	Shadowed	Legal Values (Dec)	Read/Write
0xBC (188) AGC/AEC Current Bin						
5:0	Current Bin	Status register to report the current bin of the histogram.				R
0xBF (191) Field Vertical Blank						
8:0	Field Vertical Blank	The number of blank rows between odd and even fields. Note: For interlace (both field) mode (Reg0x07 bits1:0) only.  Note: When Field Vertical Blank is set to 0, the blank time between odd and even fields is one master clock cycle.	016 (22)	Y	1–255	W
0xC0 (192) Monitor Mode Capture Control						
7:0	Image Capture Num	The number of frames to be captured during the wake-up period when monitor mode is enabled.	0A (10)	Y	1–255	W
0xC2 (194) Analog Controls						
6	Reserved	Reserved. Leave at "1"	1	N	0, 1	W
7	Anti-Eclipse Enable	Setting this bit turns on anti-eclipse circuitry.	0	N	0, 1	W
13:11	V_rst_lim voltage Level	V_rst_lim = bits [13:11] * 50mV + 1.90V Range: 1.90–2.25; Default: 1.95 V Usage: For anti-eclipse reference voltage control	1	N	0–7	W
0xC6 (198) NTSC Frame Valid Control						
0	Extend Frame Valid	When this bit is set, frame valid is extended for half-line in length at the odd field.	0	Y	0, 1	W
1	Replace FV/LV with Ped/Snyc	When this bit is set, frame valid and line valid is replaced by ped and sync signals respectively.	0	Y	0, 1	W
0xC7 (198) NTSC Horizontal Blank Control						
7:0	Front porch width	The front porch width in number of master clock cycles. NTSC standard is 1.5?sec ±0.1?sec	16 (22)	N	0–255	W
15:8	Sync Width	The sync pulse width in number of master clock cycle. NTSC standard is 4.7?sec ±0.1?sec.	44 (68)	N	0–255	W
0xC8 (200) NTSC Vertical Blank Control						
7:0	Equalizing Pulse Width	The pulse width in number of master clock cycles. NTSC standard is 2.3?sec ±0.1?sec.	21 (33)	N	0–255	W
15:8	Vertical Serration Width	The pulse width in number of master clock cycles. NTSC standard is 4.7?sec ±0.1?sec.	44 (68)	N	0–255	W
0xC9 (201) Column Start Context B						
9:0	Column Start	The first column to be read out (not counting dark columns that may be read). To window the image down, set this register to the starting X value.	000 (1)	N	0–752	W
0xCA (202) Row Start Context B						
8:0	Row Start	The first row to be read out (not counting any dark rows that may be read). To window the image down, set this register to the starting Y value. Setting a value less than four is not recommended since the dark rows should be read using R0x0D.	004 (4)	N	4–2482	W



Table 9: Register Descriptions (continued)

Bit	Bit Name	Bit Description	Default in Hex (Dec)	Shadowed	Legal Values (Dec)	Read/Write
0xCB (203) Window Height Context B						
8:0	Window Height	Number of rows in the image to be read out (not counting any dark rows or border rows that may be read).	1E0 (480)	N	1–480	W
0xCC (204) Window Width Context B						
9:0	Window Width	Number of columns in image to be read out (not counting any dark columns or border columns that may be read).	2F0 (752)	N	1–752	W
0xCD(205) Horizontal Blanking Context B						
9:0	Horizontal Blanking	Number of blank columns in a row. Minimum horizontal blanking is 61 for normal mode, 71 for column bin 2 mode, and 91 for column bin 4 mode	05E (94)	N	61–71023	W
0xCE(206) Vertical Blanking Context B						
14:0	Vertical Blanking	Number of blank rows in a frame. V-Blank value must meet the following minimums: Linear Mode: $V\text{-Blank (min)} = (SW\_total - SW1 + 7)$ $= SW\_total - R0x08 + 7$ If manual exposure, then $SW\_total = R0xD2$ . If auto-exposure mode then $SW\_total = R0xAD$ .  High Dynamic Range Mode: If Auto-Knee Point disabled, then above equations apply. If Auto-Knee Point enabled, then $V\text{-Blank (min)} = (t2 + t3 + 7)$ .  Note: Calculate t2 and t3 taking into account Auto Exposure setting.  Note: When Sequential Mode is enabled, this register is ineffective. Vertical blank = exposure + 6 rows.	002D (45)	N	2–32288	W
0xCF(207) Coarse Shutter Width 1 Context B						
14:0	Coarse Shutter Width 1	The row number in which the first knee occurs. This may be used when high dynamic range is enabled ( $R0x0F[8] = 1$ ) is enabled & exposure knee point auto adjust is disabled ( $R0xD1[8] = 0$ ). This register is not shadowed, but any change made does not take effect until the following new frame. This register minimum value is 2, for either linear or HDR modes.  Note: t1 = Shutter width 1; t2 = Shutter width 2 - Shutter width 1; t3 = total integration - Shutter width 2	1DE (478)	N	0–32765	W



Table 9: Register Descriptions (continued)

Bit	Bit Name	Bit Description	Default in Hex (Dec)	Shadowed	Legal Values (Dec)	Read/Write
<b>0xD0(208) Coarse Shutter Width 2 Context B</b>						
14:0	Coarse Shutter Width 2	The row number in which the second knee occurs. This may be used only when high dynamic range is enabled & exposure knee point auto adjust control bit is disabled. This register is not shadowed, but any change made does not take effect until the following new frame.  Note: t1 = Shutter width 1; t2 = Shutter width 2 - Shutter width 1; t3 = total integration - Shutter width 2	1DE (479)	N	0–32765	W
<b>0xD1(209) Shutter Width Control Context B</b>						
3:0	T2 Ratio	One-half to the power of this value indicates the ratio of duration time t2, when saturation control gate is adjusted to level V2, to total coarse integration when exposure knee point auto adjust control bit is enabled. This register is not shadowed, but any change made does not take effect until the following new frame.  $T2 = \text{total coarse integration} * (\frac{1}{2})^{t2\_ratio}$	4	N	0–15	W
7:4	T3 Ratio	One-half to the power of this value indicates the ratio of duration time t3, when saturation control gate is adjusted to level V3, to total coarse integration when exposure knee point auto adjust control bit is enabled. This register is not shadowed, but any change made does not take effect until the following new frame.  $T3 = \text{total coarse integration} * (\frac{1}{2})^{t3\_ratio}$  Note: t1 = total coarse integration - t2 - t3	6	N	0–15	W
8	Exposure Knee Point Auto Adjust Enable	0 = Auto adjust disabled. 1 = Auto adjust enabled.	1	N	0,1	W
9	Single Knee Enable	1 = Single knee enabled.	0	N	0,1	W
<b>0xD2 (210) Coarse Shutter Width Total Context B</b>						
14:0	Coarse Shutter Width Total	Total integration time in number of rows. This value is used only when AEC is disabled only (bit 0 of Register 175). This register is not shadowed, but any change made does not take effect until the following new frame.	1E0 (480)	N	0–32765	W



Table 9: Register Descriptions (continued)

Bit	Bit Name	Bit Description	Default in Hex (Dec)	Shadowed	Legal Values (Dec)	Read/Write
<b>0xD3 (211) Fine Shutter Width 1 Context A</b>						
10:0	Fine Shutter Width 1	This register, combined with Coarse Shutter Width 1, defines the time when the first knee occurs. This may be used only when high dynamic range is enabled and the exposure knee point auto-adjust control bit is disabled. This register is not shadowed, but any change made does not take effect until the following new frame. Register units are master clock cycles. Operational maximum is (row time - 1) = (Window Width + HBLANK - 1) Total maximum is HBLANK (R0x05) + 751 = 1023 + 751 = 1774 Notes: t1 = Shutter width 1 t2 = Shutter width 2 - Shutter width 1 t3 = Total integration - Shutter width 2	0 (0)	N	0–1774	W
<b>0xD4 (212) Fine Shutter Width 2 Context A</b>						
10:0	Fine Shutter Width 2	This register, combined with Coarse Shutter Width 2, defines the time when the second knee occurs. This may be used only when high dynamic range is enabled and the exposure knee point auto-adjust control bit is disabled. This register is not shadowed, but any change made does not take effect until the following new frame. Register units are master clock cycles. Maximum is HBLANK (R0x05) + 751 = 1023 + 751 = 1774 Notes: t1 = Shutter width 1 t2 = Shutter width 2 - Shutter width 1 t3 = Total integration - Shutter width 2	0 (0)	N	0–1774	W
<b>0xD5 (213) Fine Shutter Width Total Context A</b>						
10:0	Fine Shutter Width Total	This register, combined with Coarse Shutter Width Total, defines the total integration time. This register is not shadowed, but any change made does not take effect until the following new frame. Register units are master clock cycles. Maximum is HBLANK (R0x05) + 751 = 1023 + 751 = 1774 Note: When Coarse Shutter Width Total is zero, Minimum Fine Shutter Width = 260	0 (0)	N	0–1774	W



Table 9: Register Descriptions (continued)

Bit	Bit Name	Bit Description	Default in Hex (Dec)	Shadowed	Legal Values (Dec)	Read/Write
0xD6 (214) Fine Shutter Width 1 Context B						
10:0	Fine Shutter Width 1	This register, combined with Coarse Shutter Width 1, defines the time when the first knee occurs. This may be used only when high dynamic range is enabled and the exposure knee point auto adjust control bit is disabled. This register is not shadowed, but any change made does not take effect until the following new frame. Register units are master clock cycles. Maximum is HBLANK (R0x05) + 751 = 1023 + 751 = 1774 Notes: t1 = Shutter width 1 t2 = Shutter width 2 - Shutter width 1 t3 = Total integration - Shutter width 2	0 (0)	N	0–1774	W
0xD7 (215) Fine Shutter Width 2 Context B						
10:0	Fine Shutter Width 2	This register, combined with Coarse Shutter Width 2, defines the time when the second knee occurs. This may be used only when high dynamic range is enabled and the exposure knee point auto adjust control bit is disabled. This register is not shadowed, but any change made does not take effect until the following new frame. Register units are master clock cycles. Maximum is HBLANK (R0x05) + 751 = 1023 + 751 = 1774 Notes: t1 = Shutter width 1 t2 = Shutter width 2 - Shutter width 1 t3 = Total integration - Shutter width 2	0 (0)	N	0–1774	W
0xD8 (216) Fine Shutter Width Total Context B						
10:0	Fine Shutter Width Total	This register, combined with Coarse Shutter Width Total, defines the total integration time. This register is not shadowed, but any change made does not take effect until the following new frame. Register units are in master clock cycles. Maximum is HBLANK (R0x05) + 751 = 1023 + 751 = 1774 Note: When Coarse Shutter Width Total is zero, Minimum Fine Shutter Width = 260	0 (0)	N	0–1774	W
0xD9 (217) Monitor Mode						
10:0	Monitor Mode Enable	Setting this bit puts the sensor into a cycle of sleeping for approximately five minutes, and waking up to capture a programmable number of frames (Register 0XC0). Clearing this bit will resume normal operation.	0 (0)	Y	0–1	W



Table 9: Register Descriptions (continued)

Bit	Bit Name	Bit Description	Default in Hex (Dec)	Shadowed	Legal Values (Dec)	Read/Write
0xF0 (240) Byte-wise Address						
	Byte-wise Address	Special address to perform 8-bit reads and writes to the sensor. See Two-Wire Interface description for further details on how to use this functionality.				
0xFE (254) Register Lock						
15:0	Register Lock Code	To lock all registers except Reg0xFE, program data with 0xDEAD; to unlock access to all registers, program data with 0xBEEF.  To lock Registers 0x0D and 0x0E only, program data with 0xDEAF; to unlock, program data with 0xBEEF. While Reg0x0D and Reg0x0E are locked, any subsequent writes to those registers will be ignored until registers are unlocked.	BEEF (48,879)	N	48879 (0xBEEF), 57005 (0xDEAD), 57007 (0xDEAF)	W

## Feature Description

### Operational Modes

The MT9V024 works in master, snapshot, or slave mode. In master mode the sensor generates the readout timing. In snapshot mode it accepts an external trigger to start integration, then generates the readout timing. In slave mode the sensor accepts both external integration and readout controls. The integration time is programmed through the two-wire serial interface during master or snapshot modes, or controlled through an externally generated control signal during slave mode.

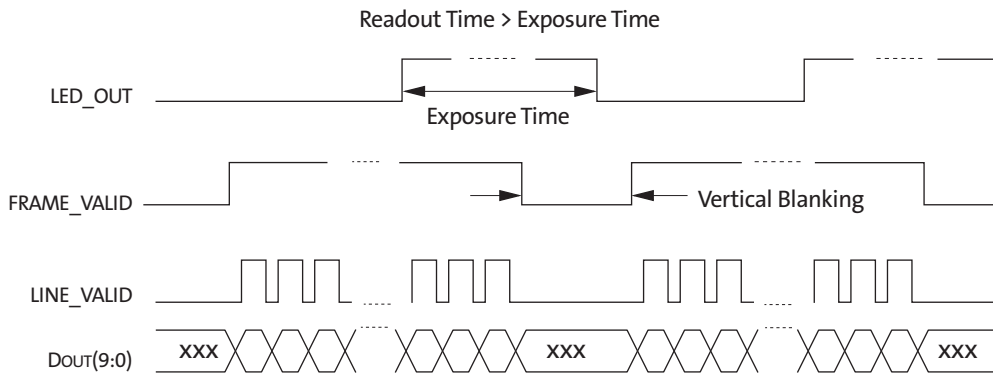
#### Master Mode

There are two possible operation methods for master mode: simultaneous and sequential. One of these operation modes must be selected through the two-wire serial interface.

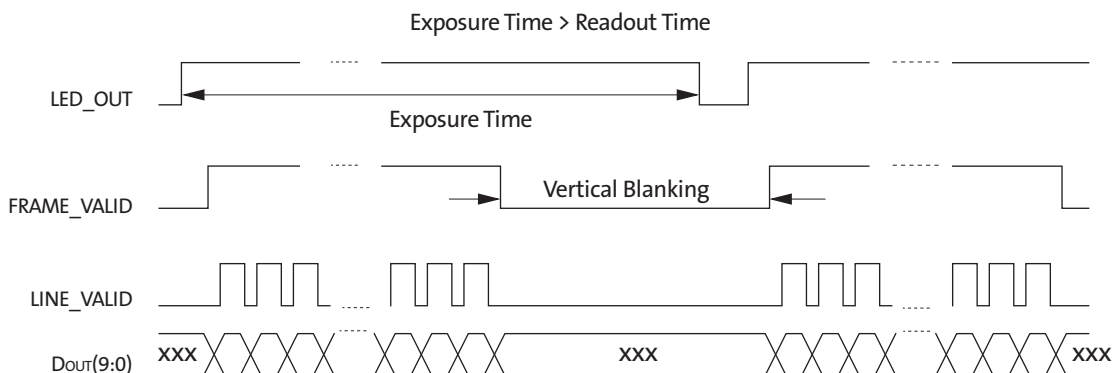
#### Simultaneous Master Mode

In simultaneous master mode, the exposure period occurs during readout. The frame synchronization waveforms are shown in Figure 13 and Figure 14. The exposure and readout happen in parallel rather than sequential, making this the fastest mode of operation.

**Figure 13: Simultaneous Master Mode Synchronization Waveforms #1**



**Figure 14: Simultaneous Master Mode Synchronization Waveforms #2**



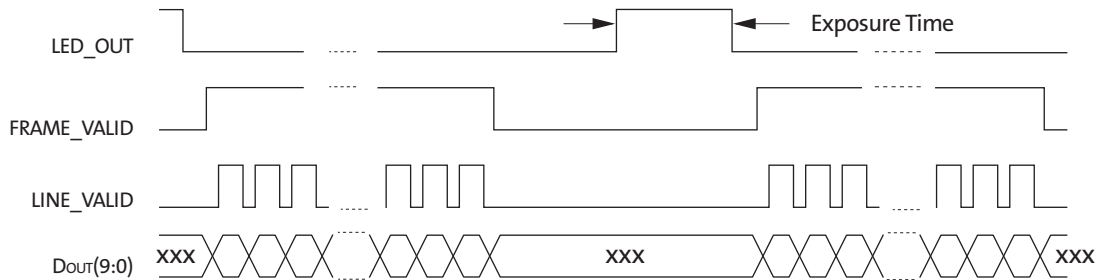


When exposure time is greater than the sum of vertical blank and window height, the number of vertical blank rows is increased automatically to accommodate the exposure time.

### Sequential Master Mode

In sequential master mode the exposure period is followed by readout. The frame synchronization waveforms for sequential master mode are shown in Figure 15. The frame rate changes as the integration time changes.

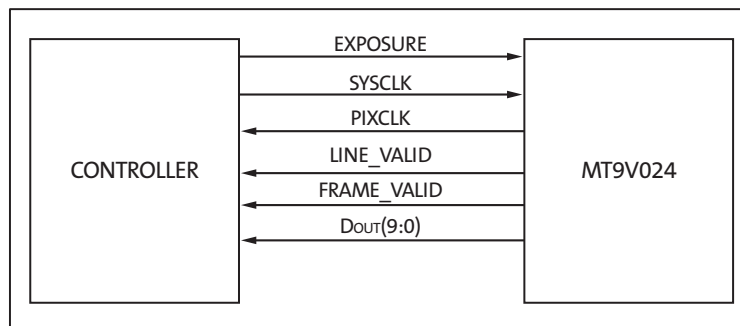
**Figure 15: Sequential Master Mode Synchronization Waveforms**



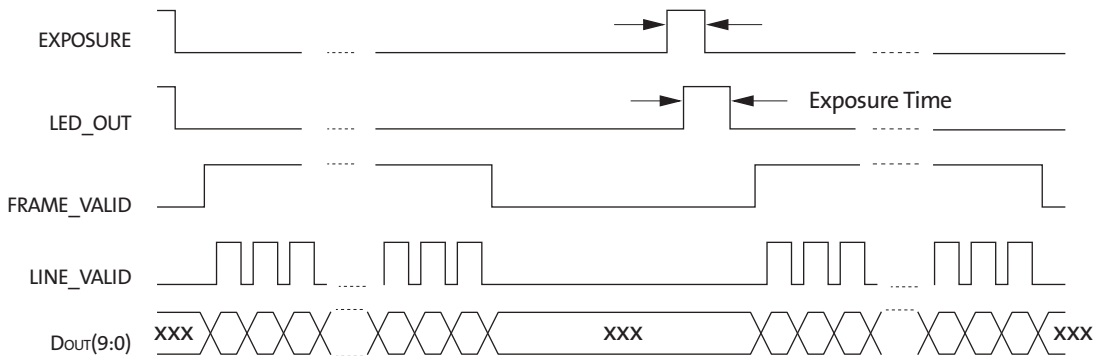
### Snapshot Mode

In snapshot mode the sensor accepts an input trigger signal which initiates exposure, and is immediately followed by readout. Figure 16 shows the interface signals used in snapshot mode. In snapshot mode, the start of the integration period is determined by the externally applied EXPOSURE pulse that is input to the MT9V024. The integration time is preprogrammed at R0x0B or R0xD2 through the two-wire serial interface. After the frame's integration period is complete the readout process commences and the syncs and data are output. Sensor in snapshot mode can capture a single image or a sequence of images. The frame rate may only be controlled by changing the period of the user supplied EXPOSURE pulse train. The frame synchronization waveforms for snapshot mode are shown in Figure 17 on page 50.

**Figure 16: Snapshot Mode Interface Signals**



**Figure 17: Snapshot Mode Frame Synchronization Waveforms**



**Slave Mode**

In slave mode, the exposure and readout are controlled using the EXPOSURE, STFRM\_OUT, and STLN\_OUT pins. When the slave mode is enabled, STFRM\_OUT and STLN\_OUT become input pins.

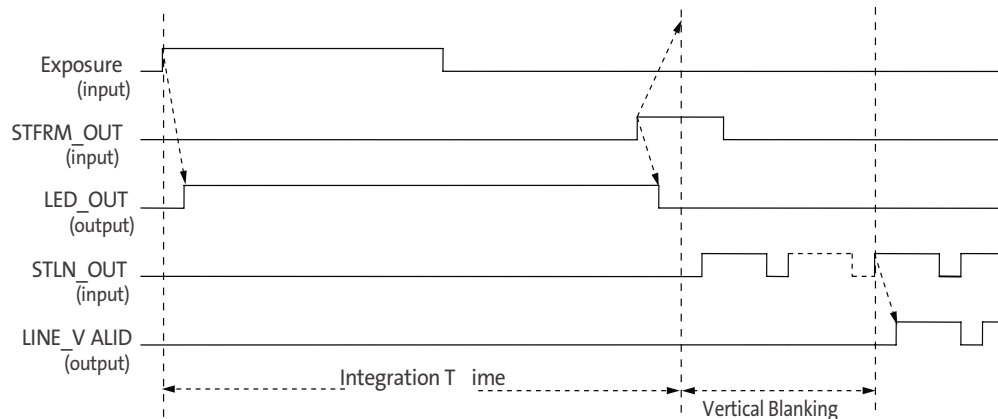
The start and end of integration are controlled by EXPOSURE and STFRM\_OUT pulses, respectively. While a STFRM\_OUT pulse is used to stop integration, it is also used to enable the readout process.

After integration is stopped, the user provides STLN\_OUT pulses to trigger row readout. A full row of data is read out with each STLN\_OUT pulse. The user must provide enough time between successive STLN\_OUT pulses to allow the complete readout of one row.

It is also important to provide additional STLN\_OUT pulses to allow the sensors to read the vertical blanking rows. It is recommended that the user program the vertical blank register (R0x06) with a value of 4, and achieve additional vertical blanking between frames by delaying the application of the STFRM\_OUT pulse.

The elapsed time between the rising edge of STLN\_OUT and the first valid pixel data is calculated for context A by [horizontal blanking register (R0x05) + 4] clock cycles. For context B, the time is (R0xCD + 4) clock cycles.

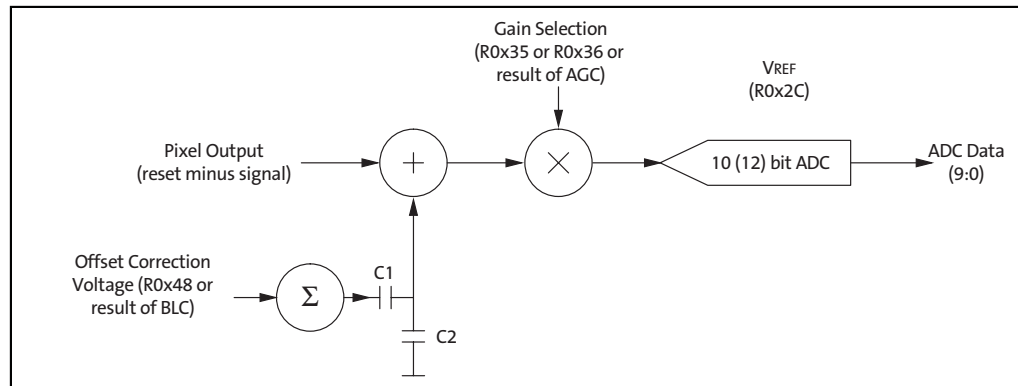
**Figure 18: Slave Mode Operation**



## Signal Path

The MT9V024 signal path consists of a programmable gain, a programmable analog offset, and a 10-bit ADC. See “Black Level Calibration” on page 60 for the programmable offset operation description.

**Figure 19: Signal Path**



## On-Chip Biases

### ADC Voltage Reference

The ADC voltage reference is programmed through R0x2C, bits 2:0. The ADC reference ranges from 1.0V to 2.1V. The default value is 1.4V. The increment size of the voltage reference is 0.1V from 1.0V to 1.6V (R0x2C[2:0] values 0 to 6). At R0x2C[2:0] = 7, the reference voltage jumps to 2.1V.

It is very important to preserve the correct values of the other bits in R0x2C. The default register setting is 0x0004. This corresponds to 1.4V—at this setting 1mV input to the ADC equals approximately 1 LSB.

### V\_Step Voltage Reference

This voltage is used for pixel high dynamic range operations, programmable from R0x31 through R0x34 for context A, or R0x39 through R0x3B for context B.

### Chip Version

Chip version register R0x00 is read-only.

## Window Control

Registers column start A/B, row start A/B, window height A/B (row size), and window width (column size) A/B control the size and starting coordinates of the window.

The values programmed in the window height and width registers are the exact window height and width out of the sensor. The window start value should never be set below four.

To read out the dark rows set bit 6 of R0x0D. In addition, bit 7 of R0x0D can be used to display the dark columns in the image. Note that there are Show Dark settings only for context A.



## Blanking Control

Horizontal blank and vertical blank registers R0x05 and R0x06 (B: 0xCD and R0xCE), respectively, control the blanking time in a row (horizontal blanking) and between frames (vertical blanking).

- Horizontal blanking is specified in terms of pixel clocks.
- Vertical blanking is specified in terms of numbers of rows.

The actual imager timing can be calculated using Table 4 on page 14 and Table 5 on page 15, which describe “Row Timing and FV/LV signals.” The minimum number of vertical blank rows is 4.

## Pixel Integration Control

### Total Integration

Total integration time is the result of coarse shutter width and fine shutter width registers, and depends also on whether manual or automatic exposure is selected.

The actual total integration time,  $t_{INT}$  is defined as:

$$t_{INT} = t_{INTCoarse} + t_{INTFine} \quad (\text{EQ 2})$$

$$= (\text{number of rows of integration} \times \text{row time}) + (\text{number of pixels of integration} \times \text{pixel time})$$

where:

- Number of Rows of Integration  
(Auto Exposure Control: Enabled)

When automatic exposure control (AEC) is enabled, the number of rows of integration may vary from frame to frame, with the limits controlled by R0xAC (minimum coarse shutter width) and R0xAD (maximum coarse shutter width).

- Number of Rows of Integration  
(Auto Exposure Control: Disabled)

If AEC is disabled, the number of rows of integration equals the value in R0x0B.

or

If context B is enabled, the number of rows of integration equals the value in R0xD2.

- Number of Pixels of Integration  
The number of fine shutter width pixels is independent of AEC mode (enabled or disabled):
  - Context A: the number of pixels of integration equals the value in R0xD5.
  - Context B: the number of pixels of integration equals the value in R0xD8.

### Row Timing

Context A: Row time =  $(R0x04 + R0x05)$  master clock periods (EQ 3)

Context B: Row time =  $(R0xCC + R0xCD)$  master clock periods (EQ 4)

Typically, the value of the Coarse Shutter Width Total registers is limited to the number of rows per frame (which includes vertical blanking rows), such that the frame rate is not affected by the integration time. If the Coarse Shutter Width Total is increased beyond the total number of rows per frame, the user must add additional blanking rows using the Vertical Blanking registers as needed. See descriptions of the Vertical Blanking registers, R0x06 and R0xCE in Table 8 on page 22 and Table 9 on page 26.

A second constraint is that  $t_{INT}$  must be adjusted to avoid banding in the image from light flicker. Under 60Hz flicker, this means the frame time must be a multiple of 1/120 of a second. Under 50Hz flicker, the frame time must be a multiple of 1/100 of a second.

## Changes to Integration Time

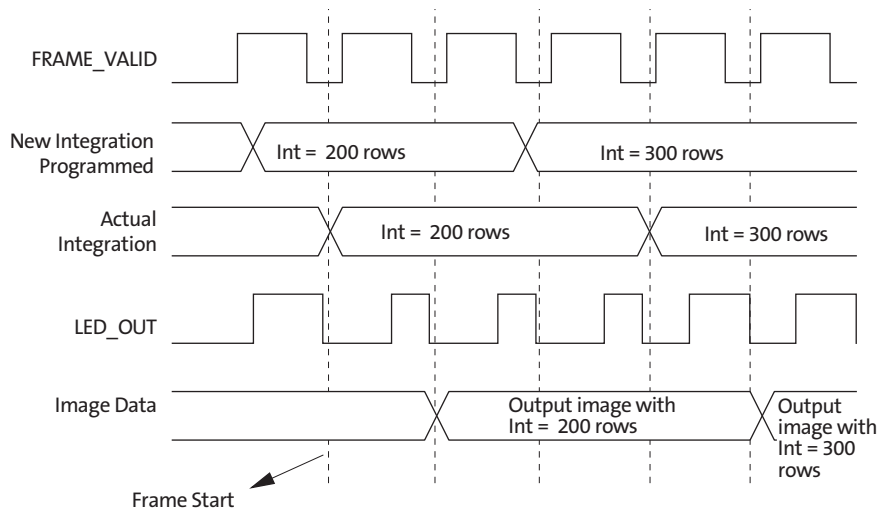
With automatic exposure control disabled (R0xAF[0] for context A, or R0xAF[8] for context B) and if the total integration time (R0x0B or R0xD2) is changed through the two-wire serial interface while FV is asserted for frame  $n$ , the first frame output using the new integration time is frame  $(n + 2)$ . Similarly, when automatic exposure control is enabled, any change to the integration time for frame  $n$  first appears in frame  $(n + 2)$  output.

The sequence is as follows:

1. During frame  $n$ , the new integration time is held in the R0x0B or R0xD2 live register.
2. At the start of frame  $(n + 1)$ , the new integration time is transferred to the exposure control module. Integration for each row of frame  $(n + 1)$  has been completed using the old integration time. The earliest time that a row can start integrating using the new integration time is immediately after that row has been read for frame  $(n + 1)$ . The actual time that rows start integrating using the new integration time is dependent on the new value of the integration time.
3. When frame  $(n + 2)$  is read out, it is integrated using the new integration time. If the integration time is changed (R0x0B or R0xD2 written) on successive frames, each value written is applied to a single frame; the latency between writing a value and it affecting the frame readout remains at two frames.

However, when automatic exposure control is disabled, if the integration time is changed through the two-wire serial interface after the falling edge of FV for frame  $n$ , the first frame output using the new integration time becomes frame  $(n + 3)$ .

**Figure 20: Latency When Changing Integration**



## Exposure Indicator

The exposure indicator is controlled by:

- R0x1B LED\_OUT Control

The MT9V024 provides an output pin, LED\_OUT, to indicate when the exposure takes place. When R0x1B bit 0 is clear, LED\_OUT is HIGH during exposure. By using R0x1B, bit 1, the polarity of the LED\_OUT pin can be inverted.

## High Dynamic Range

High dynamic range is controlled by:

	Context A	Context B
High Dynamic Enable	R0x0F[0]	R0x0F[8]
Shutter Width 1	R0x08	R0xCF
Shutter Width 2	R0x09	R0xD0
Shutter Width Control	R0x0A	R0xD1
V_Step Voltages	R0x31-R0x34	R0x39-R0x3C

In the MT9V024, high dynamic range (by setting R0x0F, bit 0 or 8 to 1) is achieved by controlling the saturation level of the pixel (HDR or high dynamic range gate) during the exposure period. The sequence of the control voltages at the HDR gate is shown in Figure 21. After the pixels are reset, the step voltage, V\_Step, which is applied to HDR gate, is set up at V1 for integration time  $t_1$ , then to V2 for time  $t_2$ , then V3 for time  $t_3$ , and finally it is parked at V4, which also serves as an antiblooming voltage for the photodetector. This sequence of voltages leads to a piecewise linear pixel response, illustrated (approximately) in Figure 21 and in Figure 22 on page 56.

**Figure 21: Sequence of Control Voltages at the HDR Gate**

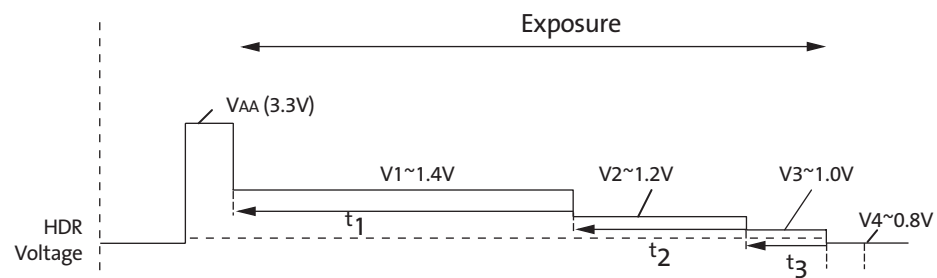
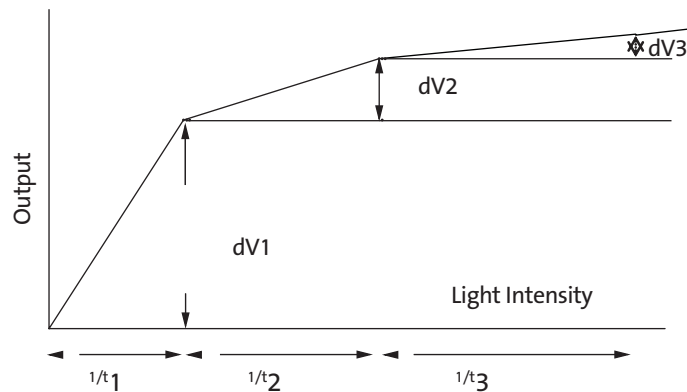


Figure 22: Sequence of Voltages in a Piecewise Linear Pixel Response



The parameters of the step voltage  $V_{Step}$ , which take values  $V1$ ,  $V2$ , and  $V3$ , directly affect the position of the knee points in Figure 22.

Light intensities work approximately as a reciprocal of the partial exposure time. Typically,  $t_1$  is the longest exposure,  $t_2$  shorter, and so on. Thus the range of light intensities is shortest for the first slope, providing the highest sensitivity.

The register settings for  $V_{Step}$  and partial exposures are:

$V1 = R0x31$ , bits 5:0 (Context B:  $R0x39$ , bits 5:0)

$V2 = R0x32$ , bits 5:0 (Context B:  $R0x3A$ , bits 5:0)

$V3 = R0x33$ , bits 5:0 (Context B:  $R0x3B$ , bits 5:0)

$V4 = R0x34$ , bits 5:0 (Context B:  $R0x3C$ , bits 5:0)

$t_{INT} = t_1 + t_2 + t_3$

There are two ways to specify the knee points timing, the first by manual setting and the second by automatic knee point adjustment. Knee point auto adjust is controlled for context A by  $R0x0A[8]$  (where default is ON), and for context B by  $R0xD1[8]$  (where default is OFF).

When the knee point auto adjust enabler is enabled (set HIGH), the MT9V024 calculates the knee points automatically using the following equations:

$$t_1 = t_{INT} - t_2 - t_3 \quad (EQ 5)$$

$$t_2 = t_{INT} \times (1/2)^{R0x0A[3:0] \text{ or } R0xD1[3:0]} \quad (EQ 6)$$

$$t_3 = t_{INT} \times (1/2)^{R0x0A[7:4] \text{ or } R0xD1[7:4]} \quad (EQ 7)$$

As a default for auto exposure,  $t_2$  is 1/16 of  $t_{INT}$ ,  $t_3$  is 1/64 of  $t_{INT}$ .

When the auto adjust enabler is disabled (set LOW),  $t_1$ ,  $t_2$ , and  $t_3$  may be programmed through the two-wire serial interface:

$$t_1 = \text{Coarse SW1 (row-times)} + \text{Fine SW1 (pixel-times)} \quad (EQ 8)$$

$$t_2 = \text{Coarse SW2} - \text{Coarse SW1} + \text{Fine SW2} - \text{Fine SW1} \quad (EQ 9)$$

$$t_3 = \text{Total Integration} - t_1 - t_2 \quad (EQ 10)$$

$$= \text{Coarse Total Shutter Width} + \text{Fine Shutter Width Total} - t_1 - t_2$$



For context A these become:

$$t_1 = R0x08 + R0xD3 \tag{EQ 11}$$

$$t_2 = R0x09 - R0x08 + R0xD4 - R0xD3 \tag{EQ 12}$$

$$t_3 = R0x0B + R0xD4 - t_1 - t_2 \tag{EQ 13}$$

For context B these are:

$$t_1 = R0xCF + R0xD6 \tag{EQ 14}$$

$$t_2 = R0xD0 - R0xCF + R0xD7 - R0xD6 \tag{EQ 15}$$

$$t_3 = R0xD2 + R0xD8 - t_1 - t_2 \tag{EQ 16}$$

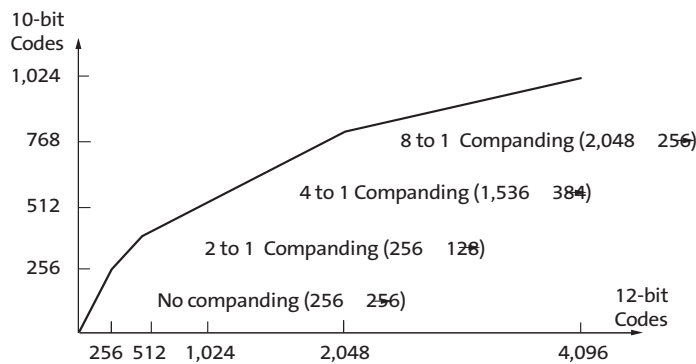
In all cases above, the coarse component of total integration time may be based on the result of AEC or values in Reg0x0B and Reg0xD2, depending on the settings.

Similar to Fine Shutter Width Total registers, the user must not set the Fine Shutter Width 1 or Fine Shutter Width 2 register to exceed the row time (Horizontal Blanking + Window Width). The absolute maximum value for the Fine Shutter Width registers is 1774 master clocks.

### ADC Companding Mode

By default, ADC resolution of the sensor is 10-bit. Additionally, a companding scheme of 12-bit into 10-bit is enabled by the ADC Companding Mode register. This mode allows higher ADC resolution, which means less quantization noise at low light, and lower resolution at high light, where good ADC quantization is not so critical because of the high level of the photon's shot noise.

**Figure 23: 12- to 10-Bit Companding Chart**



## Gain Settings

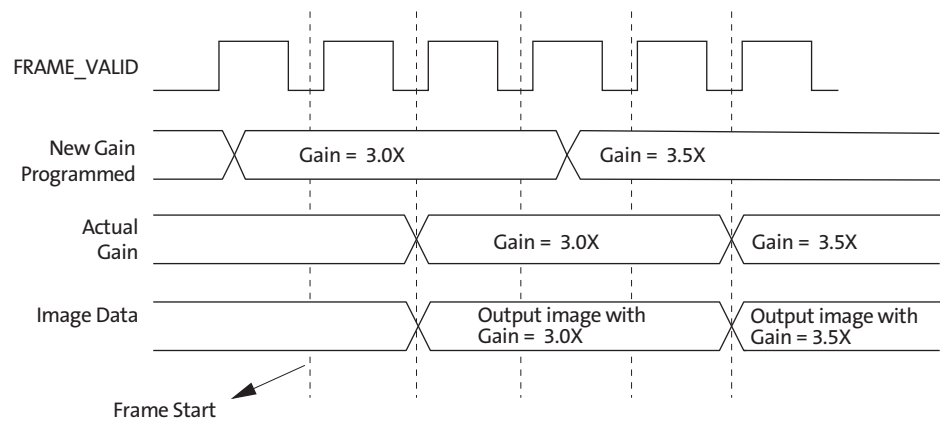
### Changes to Gain Settings

When the digital gain settings (R0x80–R0x98) are changed, the gain is updated on the next frame start. However, the latency for an analog gain change to take effect depends on the automatic gain control.

If automatic gain control is enabled (R0xAE, bit 1 is set to HIGH), the gain changed for frame  $n$  first appears in frame  $(n + 1)$ ; if the automatic gain control is disabled, the gain changed for frame  $n$  first appears in frame  $(n + 2)$ .

Both analog and digital gain change regardless of whether the integration time is also changed simultaneously. See the “MT9V024 Developer Guide” for more details.

**Figure 24: Latency of Analog Gain Change When AGC Is Disabled**



### Analog Gain

Analog gain is controlled by:

- R0x35 Global Gain context A
- R0x36 Global Gain context B

The formula for gain setting is:

$$\text{Gain} = \text{Bits}[6:0] \times 0.0625 \quad (\text{EQ 17})$$

The analog gain range supported in the MT9V024 is 1X–4X with a step size of 6.25 percent. To control gain manually with this register, the sensor must NOT be in AGC mode. When adjusting the luminosity of an image, it is recommended to alter exposure first and yield to gain increases only when the exposure value has reached a maximum limit.

Analog gain = bits (6:0)  $\times$  0.0625 for values 16–31

Analog gain = bits (6:0)/2  $\times$  0.125 for values 32–64

For values 16–31: each LSB increases analog gain 0.0625v/v. A value of 16 = 1X gain. Range: 1X to 1.9375X.

For values 32–64: each 2 LSB increases analog gain 0.125v/v (that is, double the gain increase for 2 LSB). Range: 2X to 4X. Odd values do not result in gain increases; the gain increases by 0.125 for values 32, 34, 36, and so on.

### Digital Gain

Digital gain is controlled by:

- R0x99-R0xA4 Tile Coordinates
- R0x80-R0x98 Tiled Digital Gain and Weight

In the MT9V024, the gain logic divides the image into 25 tiles, as shown in Figure 25 on page 59. The size and gain of each tile can be adjusted using the above digital gain control registers. Separate tile gains can be assigned for context A and context B.

Registers 0x99–0x9E and 0x9F–0xA4 represent the coordinates X0/5–X5/5 and Y0/5–Y5/5 in Figure 25 on page 59, respectively.

Digital gains of registers 0x80–0x98 apply to their corresponding tiles. The MT9V024 supports a digital gain of 0.25–3.75X.

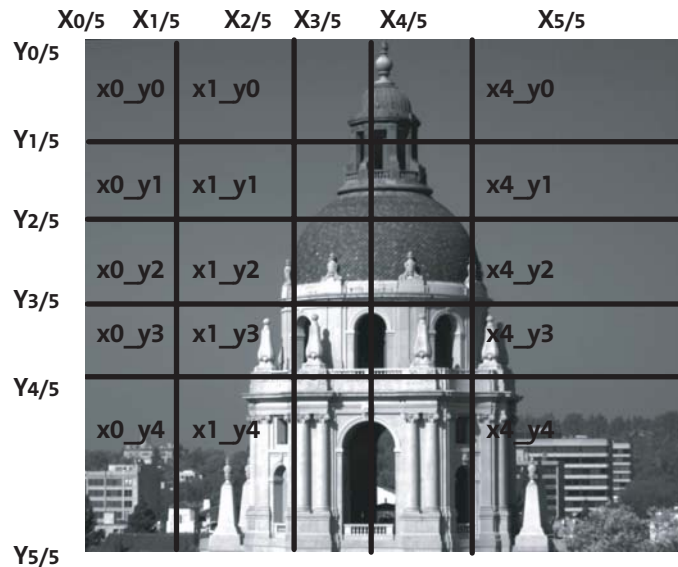
When binning is enabled, the tile offsets maintain their absolute values; that is, tile coordinates do not scale with row or column bin setting.

**Note:** There is one exception, for the condition when Column Bin 4 is enabled (R0x0D[3:2] or R0x0E[3:2] = 2). For this case, the value for Digital Tile Coordinate X-direction must be doubled.

The formula for digital gain setting is:

$$\text{Digital Gain} = \text{Bits}[3:0] \times 0.25 \tag{EQ 18}$$

**Figure 25:** Tiled Sample



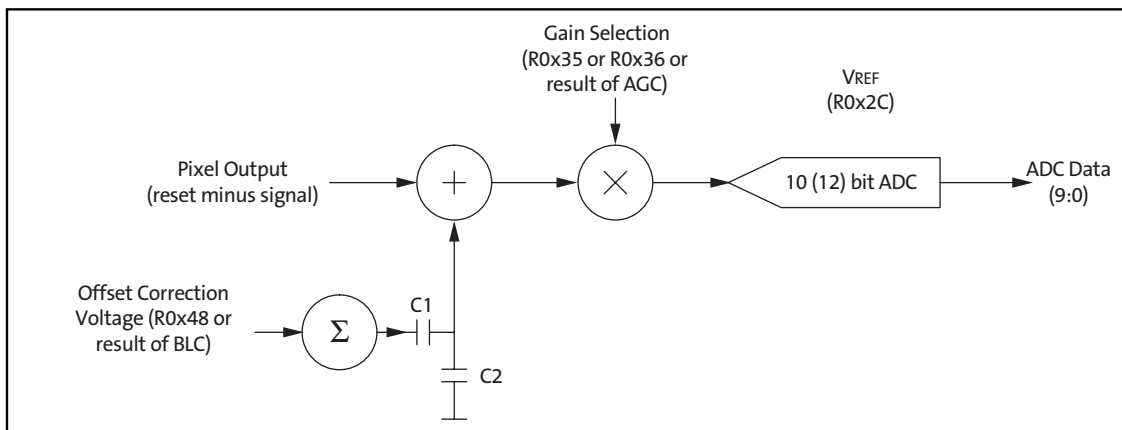
## Black Level Calibration

Black level calibration is controlled by:

- Frame Dark Average: R0x42
- Dark Average Thresholds: R0x46
- Black Level Calibration Control: R0x47
- Black Level Calibration Value: R0x48
- Black Level Calibration Value Step Size: R0x4C

The MT9V024 has automatic black level calibration on-chip, and if enabled, its result may be used in the offset correction shown in Figure 26.

**Figure 26: Black Level Calibration Flow Chart**



The automatic black level calibration measures the average value of pixels from 2 dark rows (1 dark row if row bin 4 is enabled) of the chip. (The pixels are averaged as if they were light-sensitive and passed through the appropriate gain.)

This row average is then digitally low-pass filtered over many frames (R0x47, bits 7:5) to remove temporal noise and random instabilities associated with this measurement.

Then, the new filtered average is compared to a minimum acceptable level, low threshold, and a maximum acceptable level, high threshold.

If the average is lower than the minimum acceptable level, the offset correction voltage is increased by a programmable offset LSB in R0x4C. (Default step size is 2 LSB Offset = 1 ADC LSB at analog gain = 1X.)

If it is above the maximum level, the offset correction voltage is decreased by 2 LSB (default).

To avoid oscillation of the black level from below to above, the region the thresholds should be programmed so the difference is at least two times the offset DAC step size.

In normal operation, the black level calibration value/offset correction value is calculated at the beginning of each frame and can be read through the two-wire serial interface from R0x48. This register is an 8-bit signed two's complement value.

However, if R0x47, bit 0 is set to "1," the calibration value in R0x48 is used rather than the automatic black level calculation result. This feature can be used in conjunction with the "show dark rows" feature (R0x0D[6]) if using an external black level calibration circuit.

The offset correction voltage is generated according to the following formulas:

$$\text{Offset Correction Voltage} = (8\text{-bit signed two's complement calibration value, } -127 \text{ to } 127) \times 0.5\text{mV} \quad (\text{EQ } 19)$$

$$\text{ADC input voltage} = (\text{Pixel Output Voltage} + \text{Offset Correction Voltage}) \times \text{Analog Gain} \quad (\text{EQ } 20)$$

## Defective Pixel Correction

Defective pixel correction is intended to compensate for defective pixels by replacing their value with a value based on the surrounding pixels, making the defect less noticeable to the human eye. The locations of defective pixels are stored in a ROM on chip during the manufacturing process; the maximum number of defects stored is 32. There is no provision for later augmenting the table of programmed defects. In the defect correction block, bad pixels will be substituted by either the average of its neighboring pixels, or its nearest-neighbor pixel, depending on pixel location.

Defective Pixel Correction is enabled by R0x07[9]. By default, correction is enabled, and pixels mapped in internal ROM are replaced with corrected values. This might be unacceptable to some applications, in which case pixel correction should be disabled (R0x07[9] = 0).

For complete details on using Defective Pixel Correction, refer to TN-09-141, “Defective Pixel Correction - Description and Usage”.

## Row-wise Noise Correction

Row-wise noise correction is controlled by the following registers:

- R0x70 Row Noise Control
- R0x72 Row Noise Constant

Row-wise noise cancellation is performed by calculating a row average from a set of optically black pixels at the start of each row and then applying each average to all the active pixels of the row. Read Dark Columns register bit and Row Noise Correction Enable register bit must both be set to enable row-wise noise cancellation to be performed. The behavior when Read Dark Columns register bit = 0 and Row Noise Correction Enable register bit = 1 is undefined.

The algorithm works as follows:

Logical columns 755-790 in the pixel array provide 36 optically black pixel values. Of the 36 values, two smallest value and two largest values are discarded. The remaining 32 values are averaged by summing them and discarding the 5 LSB of the result. The 10-bit result is subtracted from each pixel value on the row in turn. In addition, a positive constant will be added (Reg0x71, bits 7:0). This constant should be set to the dark level targeted by the black level algorithm plus the noise expected on the measurements of the averaged values from dark columns; it is meant to prevent clipping from negative noise fluctuations.

$$\text{Pixel value} = \text{ADC value} - \text{dark column average} + \text{R0x71}[9:0] \quad (\text{EQ } 21)$$

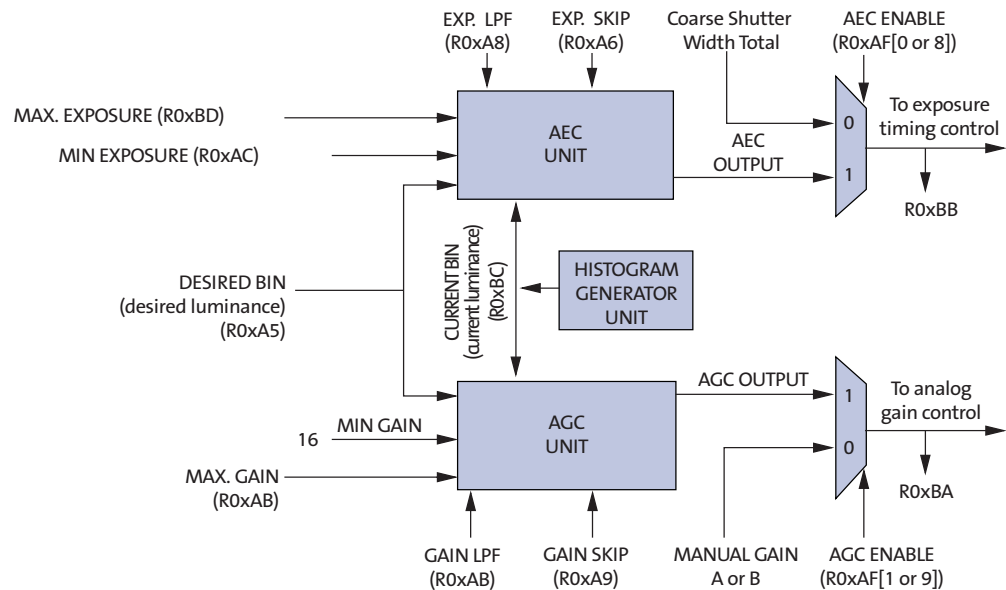
Note that this algorithm does not work in color sensor.

## Automatic Gain Control and Automatic Exposure Control

The integrated AEC/AGC unit is responsible for ensuring that optimal auto settings of exposure and (analog) gain are computed and updated every frame.

AEC and AGC can be individually enabled or disabled by R0xAF. When AEC is disabled (R0xAF[0] = 0), the sensor uses the manual exposure value in coarse and fine shutter width registers. When AGC is disabled (R0xAF[1] = 0), the sensor uses the manual gain value in R0x35 or R0x36. See “Pixel Integration Control” on page 53 and the MT9V024 Developer Guide, for more information.

**Figure 27: Controllable and Observable AEC/AGC Registers**



The exposure is measured in row-time by reading R0xBB. The exposure range is 1 to 2047. The gain is measured in gain-units by reading R0xBA. The gain range is 16 to 63 (unity gain = 16 gain-units; multiply by 1/16 to get the true gain).

When AEC is enabled (R0xAF), the maximum auto exposure value is limited by R0xBD; minimum auto exposure is limited by AEC Minimum Exposure, R0xAC.

**Note:** AEC does not support sub-row timing; calculated exposure values are rounded down to the nearest row-time. For smoother response, manual control is recommended for short exposure times.

When AGC is enabled (R0xAF), the maximum auto gain value is limited by R0xAB; minimum auto gain is fixed to 16 gain-units.

The exposure control measures current scene luminosity and desired output luminosity by accumulating a histogram of pixel values while reading out a frame. All pixels are used, whether in color or mono mode. The desired exposure and gain are then calculated from this for subsequent frame.

When binning is enabled, tuning of the AEC may be required. The histogram pixel count register, R0xB0, may be adjusted to reflect reduced pixel count. Desired bin register, R0xA5, may be adjusted as required.

## Pixel Clock Speed

The pixel clock speed is same as the master clock (SYSCLK) at 26.66 MHz by default. However, when column binning 2 or 4 (R0x0D or R0x0E, bit 2 or 3) is enabled, the pixel clock speed is reduced by half and one-fourth of the master clock speed respectively. See “Read Mode Options” on page 64 and “Column Binning” on page 65 for additional information.

## Hard Reset of Logic

The RC circuit for the MT9V024 uses a 10k $\Omega$  resistor and a 0.1 $\mu$ F capacitor. The rise time for the RC circuit is 1 $\mu$ s maximum.

## Soft Reset of Logic

Soft reset of logic is controlled by:

- R0x0C Reset

Bit 0 is used to reset the digital logic of the sensor while preserving the existing two-wire serial interface configuration. Furthermore, by asserting the soft reset, the sensor aborts the current frame it is processing and starts a new frame. Bit 1 is a shadowed reset control register bit to explicitly reset the automatic gain and exposure control feature.

These two bits are self-resetting bits and also return to “0” during two-wire serial interface reads.

## STANDBY Control

The sensor goes into standby mode by setting STANDBY to HIGH. Once the sensor detects that STANDBY is asserted, it completes the current frame before disabling the digital logic, internal clocks, and analog power enable signal. To release the sensor out from the standby mode, reset STANDBY back to LOW. The LVDS must be powered to ensure that the device is in standby mode. See "Appendix A – Power-On Reset and Standby Timing" on page 81 for more information on standby.

## Monitor Mode Control

Monitor mode is controlled by:

- R0xD9 Monitor Mode Enable
- R0xC0 Monitor Mode Image Capture Control

The sensor goes into monitor mode when R0xD9[0] is set to HIGH. In this mode, the sensor first captures a programmable number of frames (R0xC0), then goes into a sleep period for five minutes. The cycle of sleeping for five minutes and waking up to capture a number of frames continues until R0xD9[0] is cleared to return to normal operation.

In some applications when monitor mode is enabled, the purpose of capturing frames is to calibrate the gain and exposure of the scene using automatic gain and exposure control feature. This feature typically takes less than 10 frames to settle. In case a larger number of frames is needed, the value of R0xC0 may be increased to capture more frames.

During the sleep period, none of the analog circuitry and a very small fraction of digital logic (including a five-minute timer) is powered. The master clock (SYSCLK) is therefore always required.

## Read Mode Options

(Also see “Output Data Format” on page 13 and “Output Data Timing” on page 14.)

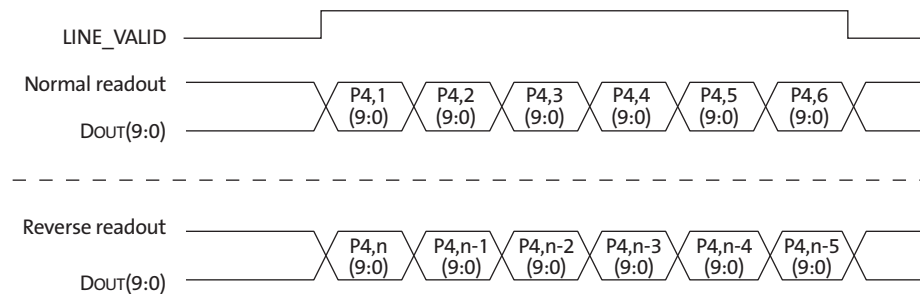
### Column Flip

By setting bit 5 of R0x0D or R0x0E the readout order of the columns is reversed, as shown in Figure 28 on page 64.

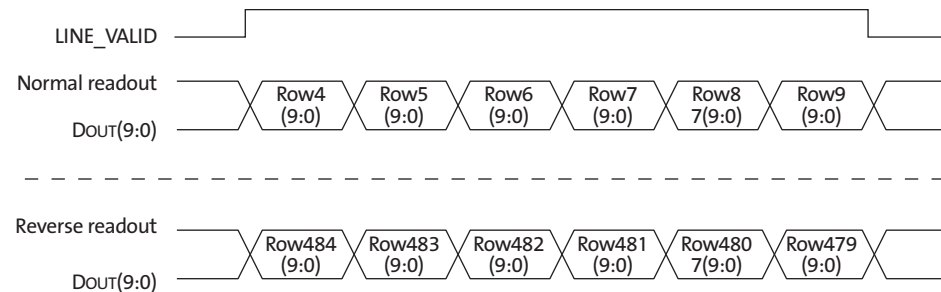
### Row Flip

By setting bit 4 of R0x0D or R0x0E the readout order of the rows is reversed, as shown in Figure 29 on page 64.

**Figure 28: Readout of Six Pixels in Normal and Column Flip Output Mode**



**Figure 29: Readout of Six Rows in Normal and Row Flip Output Mode**



## Pixel Binning

In addition to windowing mode in which smaller resolutions (CIF, QCIF) are obtained by selecting a smaller window from the sensor array, the MT9V024 also provides the ability to down-sample the entire image captured by the pixel array using pixel binning.

There are two resolution options: binning 2 and binning 4, which reduce resolution by two or by four, respectively. Row and column binning are separately selected. Image mirroring options will work in conjunction with binning.

For column binning, either two or four columns are combined by averaging to create the resulting column. For row binning, the binning result value depends on the difference in pixel values: for pixel signal differences of less than 200 LSBs, the result is the average of the pixel values. For pixel differences of greater than 200 LSBs, the result is the value of the darker pixel value.



Binning operation increases SNR but decreases resolution. Enabling row bin2 and row bin4 improves frame rate by 2x and 4x respectively. Column binning does not increase the frame rate.

### Row Binning

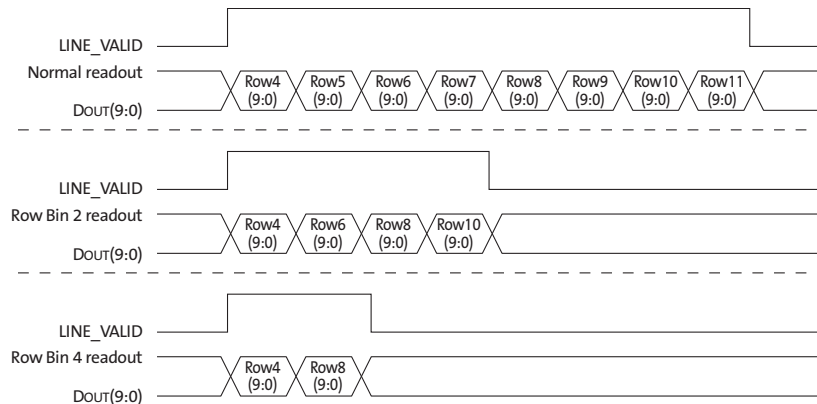
By setting bit 0 or 1 of R0x0D or R0x0E, only half or one-fourth of the row set is read out, as shown in Figure 30. The number of rows read out is half or one-fourth of the value set in R0x03. The row binning result depends on the difference in pixel values: for pixel signal differences less than 200 LSBs, the result is the average of the pixel values.

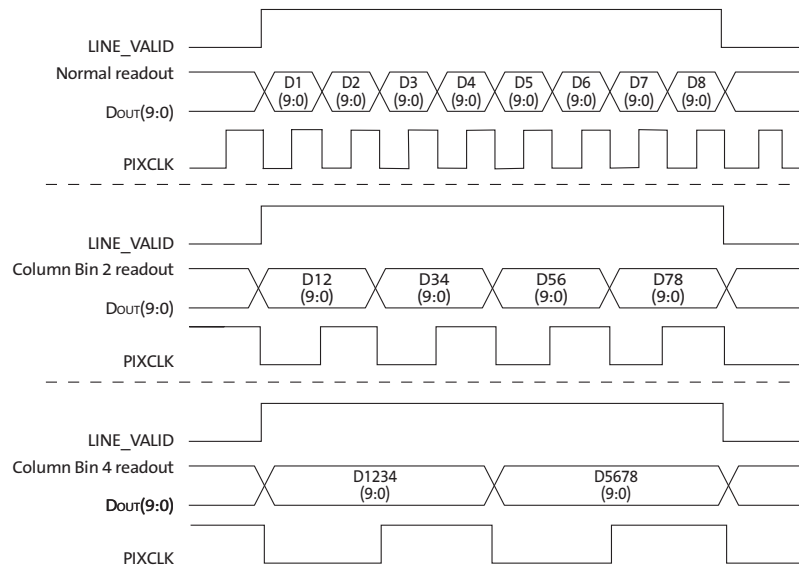
For pixel differences of 200 LSBs or more, the result is the value of the darker pixel value.

### Column Binning

For column binning, either two or four columns are combined by averaging to create the result. In setting bit 2 or 3 of R0x0D or R0x0E, the pixel data rate is slowed down by a factor of either two or four, respectively. This is due to the overhead time in the digital pixel data processing chain. As a result, the pixel clock speed is also reduced accordingly.

**Figure 30: Readout of 8 Pixels in Normal and Row Bin Output Mode**



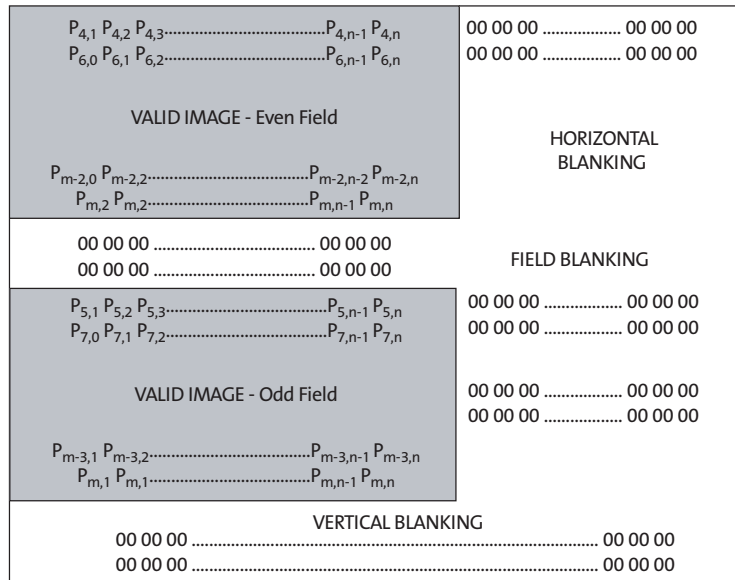
**Figure 31: Readout of 8 Pixels in Normal and Column Bin Output Mode**


### Interlaced Readout

The MT9V024 has two interlaced readout options. By setting  $R0x07[2:0] = 1$ , all the even-numbered rows are read out first, followed by a number of programmable field blanking rows (set by  $R0xBF[7:0]$ ), then the odd-numbered rows, and finally the vertical blanking rows. By setting  $R0x07[2:0] = 2$  only one field row is read out.

Consequently, the number of rows read out is half what is set in the window height register. The row start register determines which field gets read out; if the row start register is even, then the even field is read out; if row start address is odd, then the odd field is read out.

Figure 32: Spatial Illustration of Interlaced Image Readout



When interlaced mode is enabled, the total number of blanking rows are determined by both Field Blanking register (R0xBF) and Vertical Blanking register (R0x06 or R0xCE). The followings are their equations.

$$\text{Field Blanking} = R0xBF[7:0] \tag{EQ 22}$$

$$\text{Vertical Blanking} = R0x06[8:0] - R0xBF[7:0] \text{ (context A) or } R0xCE[8:0] - R0xBF[7:0] \text{ (context B)} \tag{EQ 23}$$

with

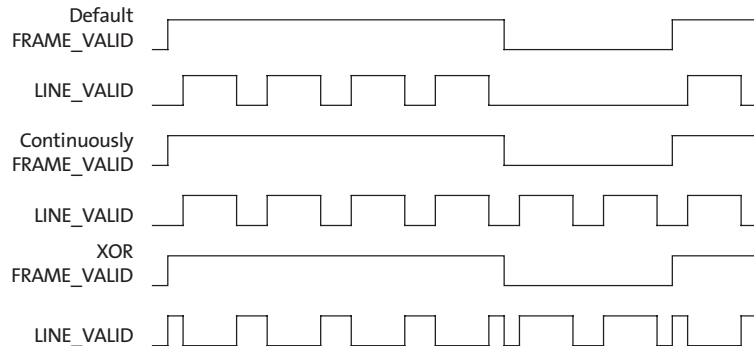
$$\text{minimum vertical blanking requirement} = 4 \text{ (absolute minimum to operate; see Vertical Blanking Registers description for VBlank minimums for valid image output)} \tag{EQ 24}$$

Similar to progressive scan, FV is logic LOW during the valid image row only. Binning should not be used in conjunction with interlaced mode.

## LINE\_VALID

By setting bit 2 and 3 of R0x72, the LV signal can get three different output formats. The formats for reading out four rows and two vertical blanking rows are shown in Figure 33. In the last format, the LV signal is the XOR between the continuous LV signal and the FV signal.

**Figure 33: Different LINE\_VALID Formats**



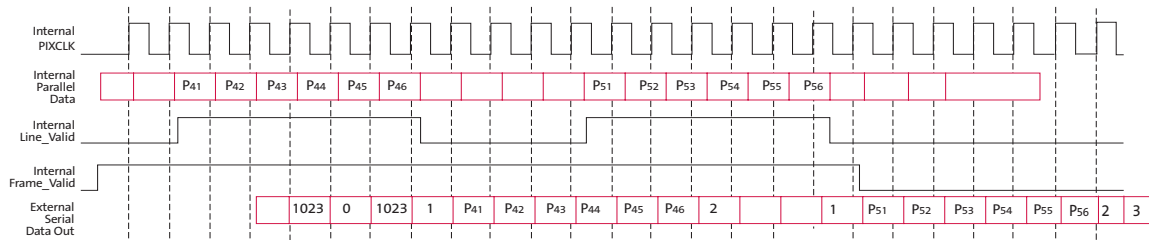
## LVDS Serial (Stand-Alone/Stereo) Output

The LVDS interface allows for the streaming of sensor data serially to a standard off-the-shelf deserializer up to eight meters away from the sensor. The pixels (and controls) are packeted—12-bit packets for stand-alone mode and 18-bit packets for stereoscopy mode. All serial signaling (CLK and data) is LVDS. The LVDS serial output could either be data from a single sensor (stand-alone) or stream-merged data from two sensors (self and its stereoscopic slave pair). The appendices describe in detail the topologies for both stand-alone and stereoscopic modes.

There are two standard deserializers that can be used. One for a stand-alone sensor stream and the other from a stereoscopic stream. The deserializer attached to a stand-alone sensor is able to reproduce the standard parallel output (8-bit pixel data, LV, FV, and PIXCLK). The deserializer attached to a stereoscopic sensor is able to reproduce 8-bit pixel data from each sensor (with embedded LV and FV) and pixel-clk. An additional (simple) piece of logic is required to extract LV and FV from the 8-bit pixel data. Irrespective of the mode (stereoscopy/stand-alone), LV and FV are always embedded in the pixel data.

In stereoscopic mode, the two sensors run in lock-step, implying all state machines are in the same state at any given time. This is ensured by the sensor-pair getting their sys-clks and sys-resets in the same instance. Configuration writes through the two-wire serial interface are done in such a way that both sensors can get their configuration updates at once. The inter-sensor serial link is designed in such a way that once the slave PLL locks and the data-dly, shft-clk-dly and stream-latency-sel are configured, the master sensor streams valid stereo content irrespective of any variation voltage and/or temperature as long as it is within specification. The configuration values of data-dly, shft-clk-dly and stream-latency-sel are either predetermined from the board-layout or can be empirically determined by reading back the stereo-error flag. This flag is asserted when the two sensor streams are not in sync when merged. The combo\_reg is used for out-of-sync diagnosis.

Figure 34: Serial Output Format for a 6x2 Frame



- Notes:
1. External pixel values of 0, 1, 2, 3, are reserved (they only convey control information). Any raw pixel of value 0, 1, 2 and 3 will be substituted with 4.
  2. The external pixel sequence 1023, 0, 1023 is a reserved sequence (conveys control information for legacy support of MT9V021 applications). Any raw pixel sequence of 1023, 0, 1023 will be substituted with an output serial stream of 1023, 4, 1023.

### LVDS Output Format

In stand-alone mode, the packet size is 12 bits (2 frame bits and 10 payload bits); 10-bit pixels or 8-bit pixels can be selected. In 8-bit pixel mode (R0xB6[0] = 0), the packet consists of a start bit, 8-bit pixel data (with sync codes), the line valid bit, the frame valid bit and the stop bit. For 10-bit pixel mode (R0xB6[0] = 1), the packet consists of a start bit, 10-bit pixel data, and the stop bit.

Table 10: LVDS Packet Format in Stand-Alone Mode  
(Stereoscopy Mode Bit De-Asserted)

12-Bit Packet	use_10-bit_pixels Bit De-Asserted (8-Bit Mode)	use_10-bit_pixels Bit Asserted (10-Bit Mode)
Bit[0]	1'b1 (Start bit)	1'b1 (Start bit)
Bit[1]	PixelData[2]	PixelData[0]
Bit[2]	PixelData[3]	PixelData[1]
Bit[3]	PixelData[4]	PixelData[2]
Bit[4]	PixelData[5]	PixelData[3]
Bit[5]	PixelData[6]	PixelData[4]
Bit[6]	PixelData[7]	PixelData[5]
Bit[7]	PixelData[8]	PixelData[6]
Bit[8]	PixelData[9]	PixelData[7]
Bit[9]	Line_Valid	PixelData[8]
Bit[10]	Frame_Valid	PixelData[9]
Bit[11]	1'b0 (Stop bit)	1'b0 (Stop bit)

In stereoscopic mode, the packet size is 18 bits (2 frame bits and 16 payload bits). The packet consists of a start bit, the master pixel byte (with sync codes), the slave byte (with sync codes), and the stop bit.)

**Table 11: LVDS Packet Format in Stereoscropy Mode (Stereoscropy Mode Bit Asserted)**

18-bit Packet	Function
Bit[0]	1'b1 (Start bit)
Bit[1]	MasterSensorPixelData[2]
Bit[2]	MasterSensorPixelData[3]
Bit[3]	MasterSensorPixelData[4]
Bit[4]	MasterSensorPixelData[5]
Bit[5]	MasterSensorPixelData[6]
Bit[6]	MasterSensorPixelData[7]
Bit[7]	MasterSensorPixelData[8]
Bit[8]	MasterSensorPixelData[9]
Bit[9]	SlaveSensorPixelData[2]
Bit[10]	SlaveSensorPixelData[3]
Bit[11]	SlaveSensorPixelData[4]
Bit[12]	SlaveSensorPixelData[5]
Bit[13]	SlaveSensorPixelData[6]
Bit[14]	SlaveSensorPixelData[7]
Bit[15]	SlaveSensorPixelData[8]
Bit[16]	SlaveSensorPixelData[9]
Bit[17]	1'b0 (Stop bit)

Control signals LV and FV can be reconstructed from their respective preceding and succeeding flags that are always embedded within the pixel data in the form of reserved words.

**Table 12: Reserved Words in the Pixel Data Stream**

Pixel Data Reserved Word	Flag
0	Precedes frame valid assertion
1	Precedes line valid assertion
2	Succeeds line valid de-assertion
3	Succeeds frame valid de-assertion

When LVDS mode is enabled along with column binning (bin 2 or bin 4, R0x0D[3:2]), the packet size remains the same but the serial pixel data stream repeats itself depending on whether 2X or 4X binning is set:

- For bin 2, LVDS outputs double the expected data (post-binning pixel 0,0 is output twice in sequence, followed by pixel 0,1 twice, . . .).
- For bin 4, LVDS outputs 4 times the expected data (pixel 0,0 is output 4 times in sequence followed by pixel 0,1 times 4, . . .).

The receiving hardware will need to undersample the output stream ,getting data either every 2 clocks (bin 2) or every 4 (bin 4) clocks.

If the sensor provides a pixel whose value is 0,1, 2, or 3 (that is, the same as a reserved word) then the outgoing serial pixel value is switched to 4.



## LVDS Enable and Disable

The Table 13 and Table 14 further explain the state of the LVDS output pins depending on LVDS control settings. When the LVDS block is not used, it may be left powered down to reduce power consumption.

Table 13: SER\_DATAOUT\_\* state

R0xB1[1] LVDS power down	R0xB3[4] LVDS data power down	SER_DATAOUT_*
0	0	Active
0	1	Active
1	0	Z
1	1	Z

Table 14: SHFT\_CLK\_\* state

R0xB1[1] LVDS power down	R0xB2[4] LVDS shift-clk power down	SHFT_CLKOUT_*
0	0	Active
0	1	Z
1	0	Z
1	1	Z

Note: ERROR pin: When the sensor is not in stereo mode, the ERROR pin is at LOW.

### LVDS Data Bus Timing

The LVDS bus timing waveforms and timing specifications are shown in Table 15 and Figure 35.

Figure 35: LVDS Timing

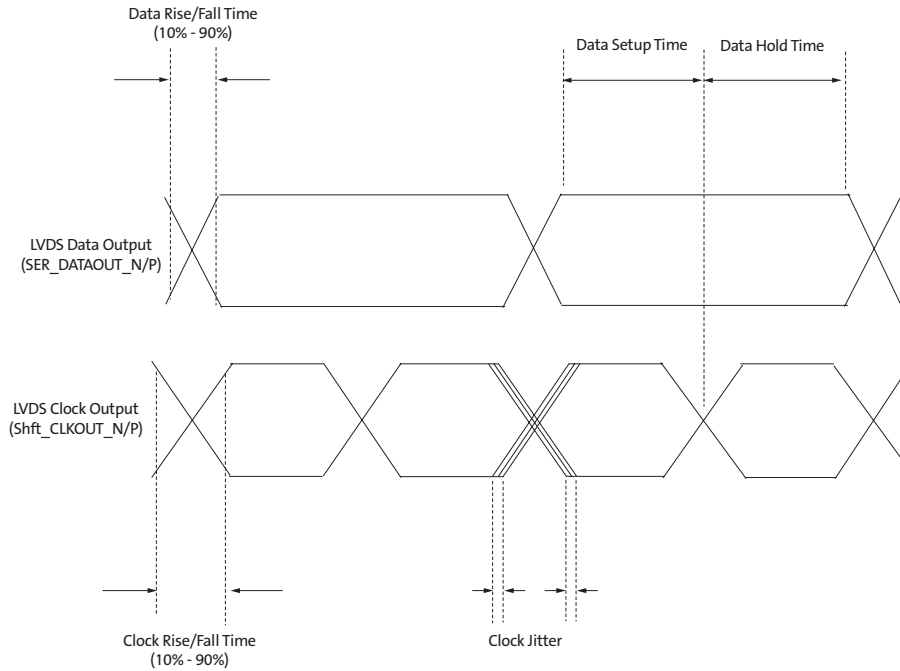


Table 15: LVDS AC Timing Specifications

VPWR = 3.3V ±0.3V; T<sub>J</sub> = -40°C to +105°C; output load = 100 Ω; frequency 27 MHz

Parameter	Minimum	Typical	Maximum	Unit
LVDS clock rise time	—	0.22	0.30	ns
LVDS clock fall time	—	0.22	0.30	ns
LVDS data rise time	—	0.28	0.30	ns
LVDS data fall time	—	0.28	0.30	ns
LVDS data setup time	0.3	0.67	—	ns
LVDS data hold time	0.1	1.34	—	ns
LVDS clock jitter	—	—	92	ps





## Electrical Specifications

**Table 16: DC Electrical Characteristics Over Temperature**

VPWR = 3.3V ±0.3V; T<sub>J</sub> = -40°C to +105°C; Output Load = 10pF; Frequency 13 MHz to 27 MHz; LVDS off

Symbol	Definition	Condition	Minimum	Typical	Maximum	Unit
V <sub>IH</sub>	Input HIGH voltage		VPWR - 1.4	–		V
V <sub>IL</sub>	Input LOW voltage			–	1.3	V
I <sub>IN</sub>	Input leakage current	No pull-up resistor; V <sub>IN</sub> = VPWR or VGND	-5	–	5	μA
V <sub>OH</sub>	Output HIGH voltage	I <sub>OH</sub> = -4.0mA	VPWR - 0.3	–	–	V
V <sub>OL</sub>	Output LOW voltage	I <sub>OL</sub> = 4.0mA	–	–	0.3	V
I <sub>OH</sub>	Output HIGH current	V <sub>OH</sub> = V <sub>DD</sub> - 0.7	-11	–	–	mA
I <sub>OL</sub>	Output LOW current	V <sub>OL</sub> = 0.7	–	–	11	mA
IPWRA	Analog supply current	Default settings	–	12	20	mA
IPIX	Pixel supply current	Default settings	–	1.1	3	mA
IPWRD	Digital supply current	Default settings, C <sub>LOAD</sub> = 10pF	–	42	60	mA
ILVDS	LVDS supply current	Default settings with LVDS on	–	13	16	mA
IPWRA Standby	Analog standby supply current	STDBY = V <sub>DD</sub>	–	0.2	3	μA
IPWRD Standby Clock Off	Digital standby supply current with clock off	STDBY = V <sub>DD</sub> , CLKIN = 0 MHz	–	0.1	10	μA
IPWRD Standby Clock On	Digital standby supply current with clock on	STDBY = V <sub>DD</sub> , CLKIN = 27 MHz	–	1	2	mA

**Table 17: DC Electrical Characteristics**

VPWR = 3.3V ±0.3V; T<sub>A</sub> = Ambient = 25°C

Symbol	Definition	Condition	Minimum	Typical	Maximum	Unit
<b>LVDS Driver DC Specifications</b>						
V <sub>OD</sub>	Output differential voltage	R <sub>LOAD</sub> = 100  Ω ± 1%	250	–	400	mV
DV <sub>OD</sub>	Change in V <sub>OD</sub> between complementary output states		–	–	50	mV
V <sub>OS</sub>	Output offset voltage		1.0	1.2	1.4	mV
DV <sub>OS</sub>	Pixel array current		–	–	35	mV
I <sub>OS</sub>	Digital supply current			±10		mA
I <sub>OZ</sub>	Output current when driver is tri-state			±1		μA
<b>LVDS Receiver DC Specifications</b>						
V <sub>IDTH+</sub>	Input differential	V <sub>GPD</sub>   < 925mV	-100	–	100	mV
I <sub>IN</sub>	Input current		–	–	±20	μA

**Table 18: Absolute Maximum Ratings**

**Caution** Stresses greater than those listed may cause permanent damage to the device.

Symbol	Parameter	Minimum	Maximum	Unit
V <sub>SUPPLY</sub>	Power supply voltage (all supplies)	-0.3	4.5	V
I <sub>SUPPLY</sub>	Total power supply current	-	200	mA
I <sub>GND</sub>	Total ground current	-	200	mA
V <sub>IN</sub>	DC input voltage	-0.3	V <sub>DD</sub> + 0.3	V
V <sub>OUT</sub>	DC output voltage	-0.3	V <sub>DD</sub> + 0.3	V
T <sub>STG</sub> <sup>Note:</sup>	Storage temperature	-50	+150	°C

Note: This is a stress rating only, and functional operation of the device at these or any other conditions above those indicated in the operational sections of this specification is not implied. Exposure to absolute maximum rating conditions for extended periods may affect reliability.

**Table 19: AC Electrical Characteristics**

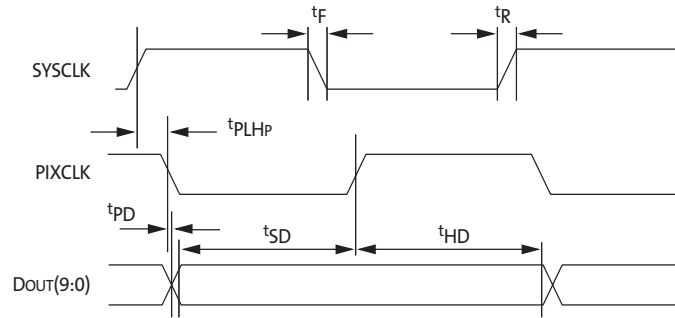
V<sub>PWR</sub> = 3.3V ±0.3V; T<sub>J</sub> = -40°C to +105°C; Output Load = 10pF

Symbol	Definition	Condition	Minimum	Typical	Maximum	Unit
SYSCCLK	Input clock frequency		13.0	26.6	27.0	MHz
	Clock duty cycle		45.0	50.0	55.0	%
t <sub>R</sub>	Input clock rise time		-	3	5	ns
t <sub>F</sub>	Input clock fall time		-	3	5	ns
t <sub>PLHP</sub>	SYSCCLK to PIXCLK propagation delay	CLOAD = 10pF	4	6	8	ns
t <sub>PD</sub>	PIXCLK to valid Dout(9:0) propagation delay	CLOAD = 10pF	-3	0.6	3	ns
t <sub>SD</sub>	Data setup time		14	16	-	ns
t <sub>HD</sub>	Data hold time		14	16	-	
t <sub>PFLR</sub>	PIXCLK to LV propagation delay	CLOAD = 10pF	5	7	9	ns
t <sub>PFLF</sub>	PIXCLK to FV propagation delay	CLOAD = 10pF	5	7	9	ns

### Propagation Delays for PIXCLK and Data Out Signals

The pixel clock is inverted and delayed relative to the master clock. The relative delay from the master clock (SYSCLK) rising edge to both the pixel clock (PIXCLK) falling edge and the data output transition is typically 7ns. Note that the falling edge of the pixel clock occurs at approximately the same time as the data output transitions. See Table 19 on page 74 for data setup and hold times.

**Figure 36: Propagation Delays for PIXCLK and Data Out Signals**

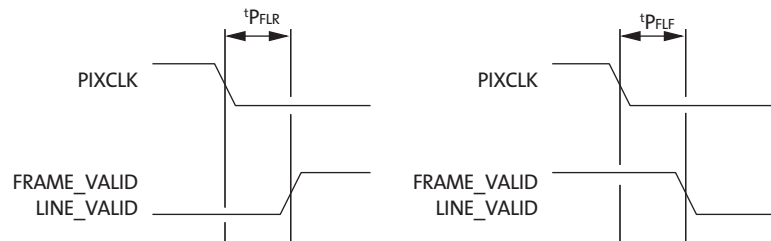


### Propagation Delays for FRAME\_VALID and LINE\_VALID Signals

The LV and FV signals change on the same rising master clock edge as the data output. The LV goes HIGH on the same rising master clock edge as the output of the first valid pixel's data and returns LOW on the same master clock rising edge as the end of the output of the last valid pixel's data.

As shown in the “Output Data Timing” on page 14, FV goes HIGH 143 pixel clocks before the first LV goes HIGH. It returns LOW 23 pixel clocks after the last LV goes LOW.

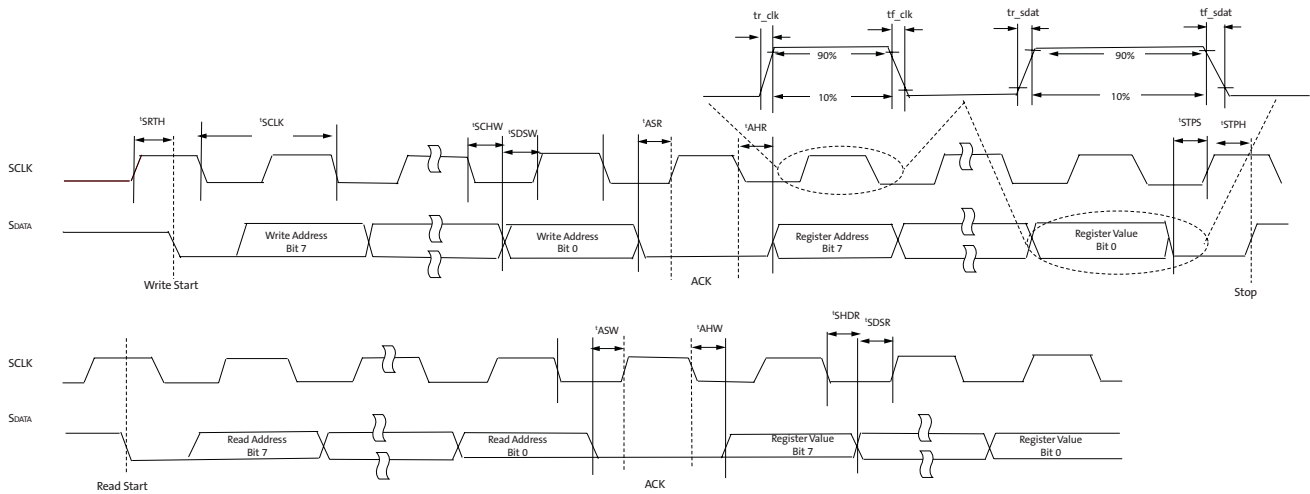
**Figure 37: Propagation Delays for FRAME\_VALID and LINE\_VALID Signals**



## Two-Wire Serial Bus Timing

Detailed timing waveforms and parameters for the two-wire serial interface bus are shown in Figure 38 and Table 20.

**Figure 38: Two-wire Serial Bus Timing**



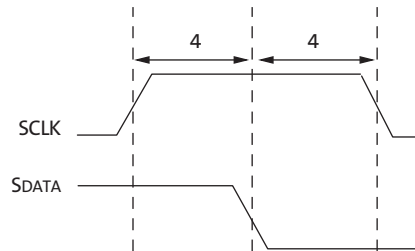
**Table 20: Two-Wire Serial Bus Timing Parameters**  
Test Conditions: 25°C, 26.67 MHz, and 3.3V

Symbol	Parameter	Condition	Minimum	Typical	Maximum	Unit
$t_{SCLK}$	Serial interface input clock frequency				400	kHz
$t_{SCLK}$	Serial Input clock period				2.5	$\mu$ sec
	SCLK duty cycle	When active	40	50	60	%
$t_{r\_sclk}$	SCLK rise time			165		ns
$t_{f\_sclk}$	SCLK fall time			6		ns
$t_{r\_sdat}$	SDATA rise time	1.5 k $\Omega$ pull-up		180		ns
$t_{f\_sdat}$	SDATA fall time			9		ns
$t_{SRTS}$	Start setup time	WRITE/READ	148	150	167	ns
$t_{SRTH}$	Start hold time	WRITE/READ	36.9	36	37.6	ns
$t_{SDSW}$	SDATA setup	WRITE	0	5	12	ns
$t_{SDHW}$	SDATA hold	WRITE	1.3	36	37	ns
$t_{ASW}$	ACK setup time	WRITE	146	146	148	ns
$t_{AHW}$	ACK hold time	WRITE	98.9	107	144	ns
$t_{STPS}$	Stop setup time	WRITE/READ		624		ns
$t_{STPH}$	Stop hold time	WRITE/READ		1.61		ns
$t_{ASR}$	ACK setup time	READ	192	228	229	ns
$t_{AHR}$	ACK hold time	READ	247	284	287	ns
$t_{SDSR}$	SDATA setup	READ	654	655	690	ns
$t_{SDHR}$	SDATA hold	READ	560	595	596	ns
CIN_SI	Serial interface input pin capacitance			3.5		pF
CLOAD_SD	SDATA max load capacitance			15		pF
RSD	SDATA external pull-up resistor			1.5		k $\Omega$

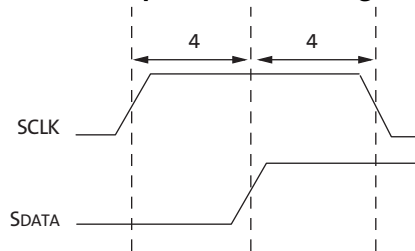
**Minimum Master Clock Cycles**

In addition to the AC timing requirements described in Table 20 on page 76, the two-wire serial bus operation also requires certain minimum master clock cycles between transitions. These are specified in Figures 39 through 44, in units of master clock cycles.

**Figure 39: Serial Host Interface Start Condition Timing**

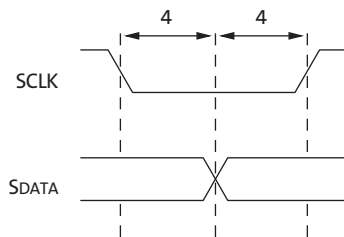


**Figure 40: Serial Host Interface Stop Condition Timing**



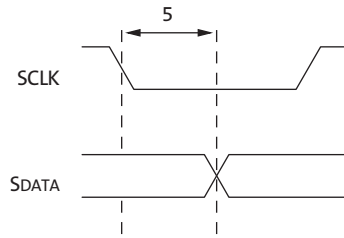
Note: All timing are in units of master clock cycle.

**Figure 41: Serial Host Interface Data Timing for WRITE**



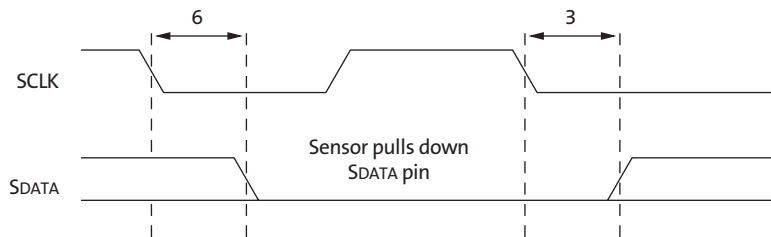
Note: SDATA is driven by an off-chip transmitter.

**Figure 42: Serial Host Interface Data Timing for READ**

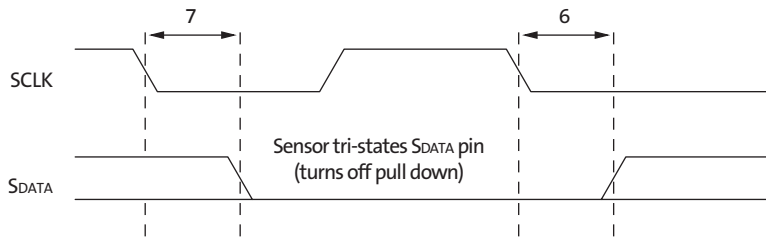


Note: SDATA is pulled LOW by the sensor, or allowed to be pulled HIGH by a pull-up resistor off-chip.

**Figure 43: Acknowledge Signal Timing After an 8-Bit WRITE to the Sensor**



**Figure 44: Acknowledge Signal Timing After an 8-Bit READ from the Sensor**



Note: After a READ, the master receiver must pull down SDATA to acknowledge receipt of data bits. When the read sequence is complete, the master must generate a “No Acknowledge” by leaving SDATA to float HIGH. On the following cycle, a start or stop bit may be used.

Figure 45: Typical Quantum Efficiency—Color

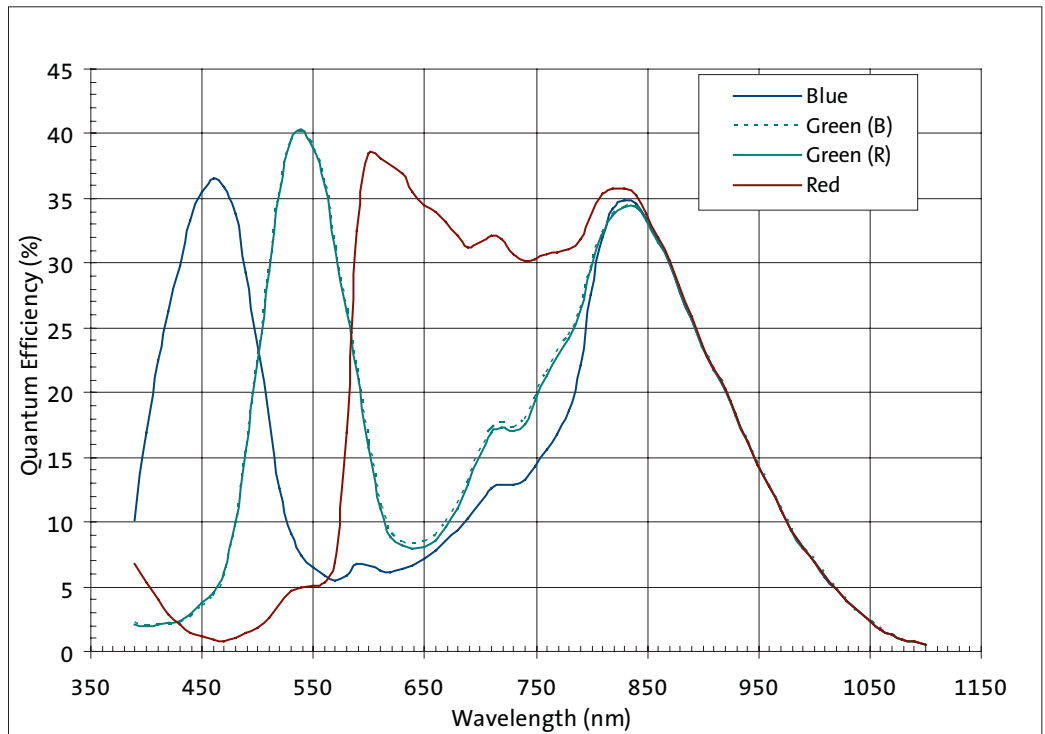
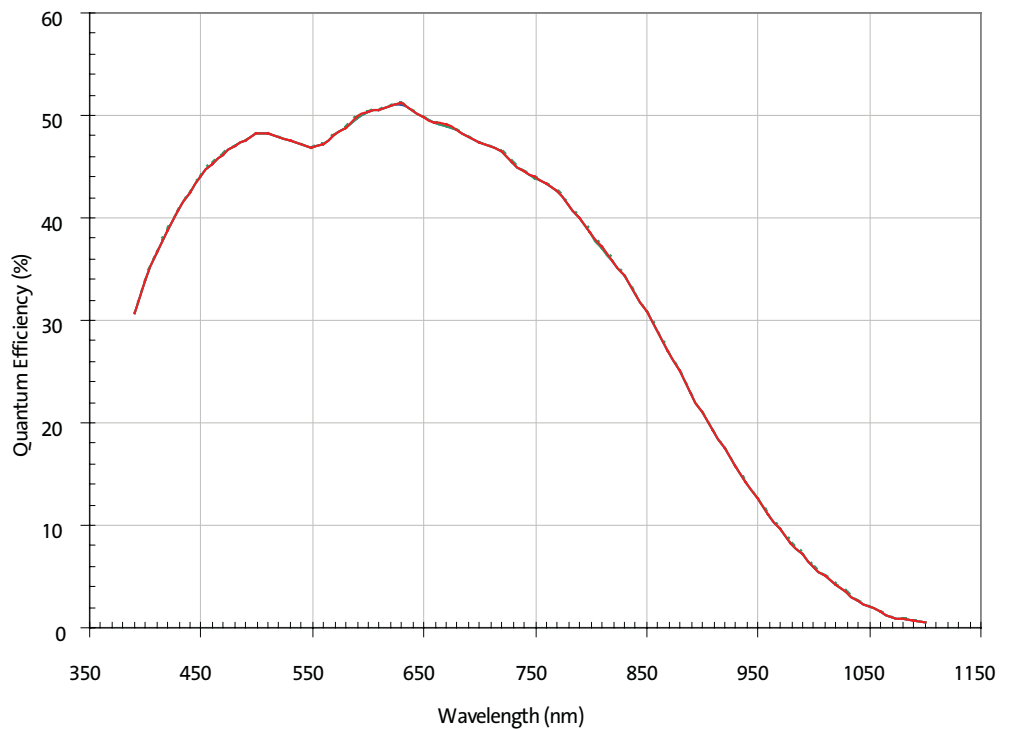
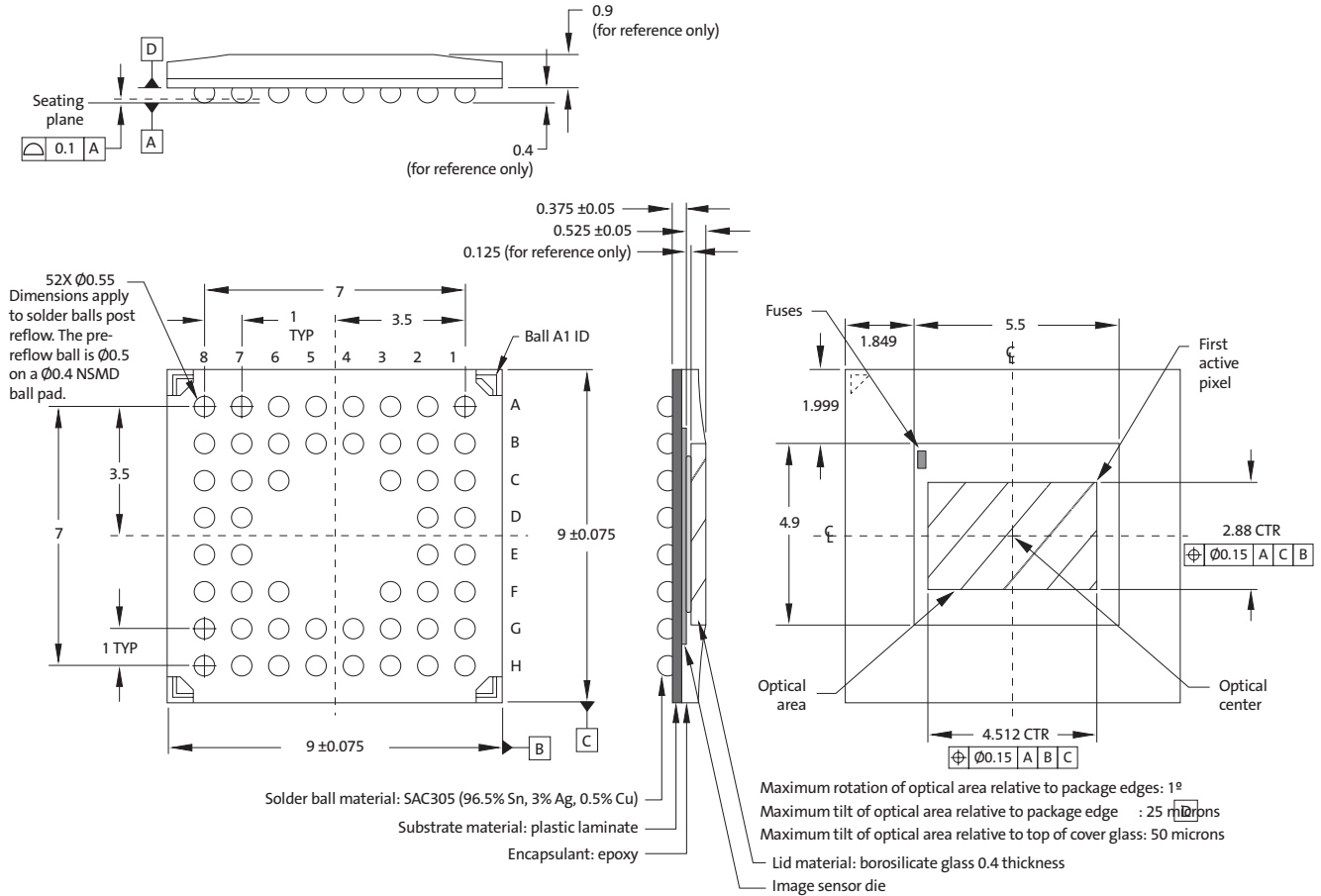


Figure 46: Typical Quantum Efficiency—Monochrome



## Package Dimensions

Figure 47: 52-Ball IBGA



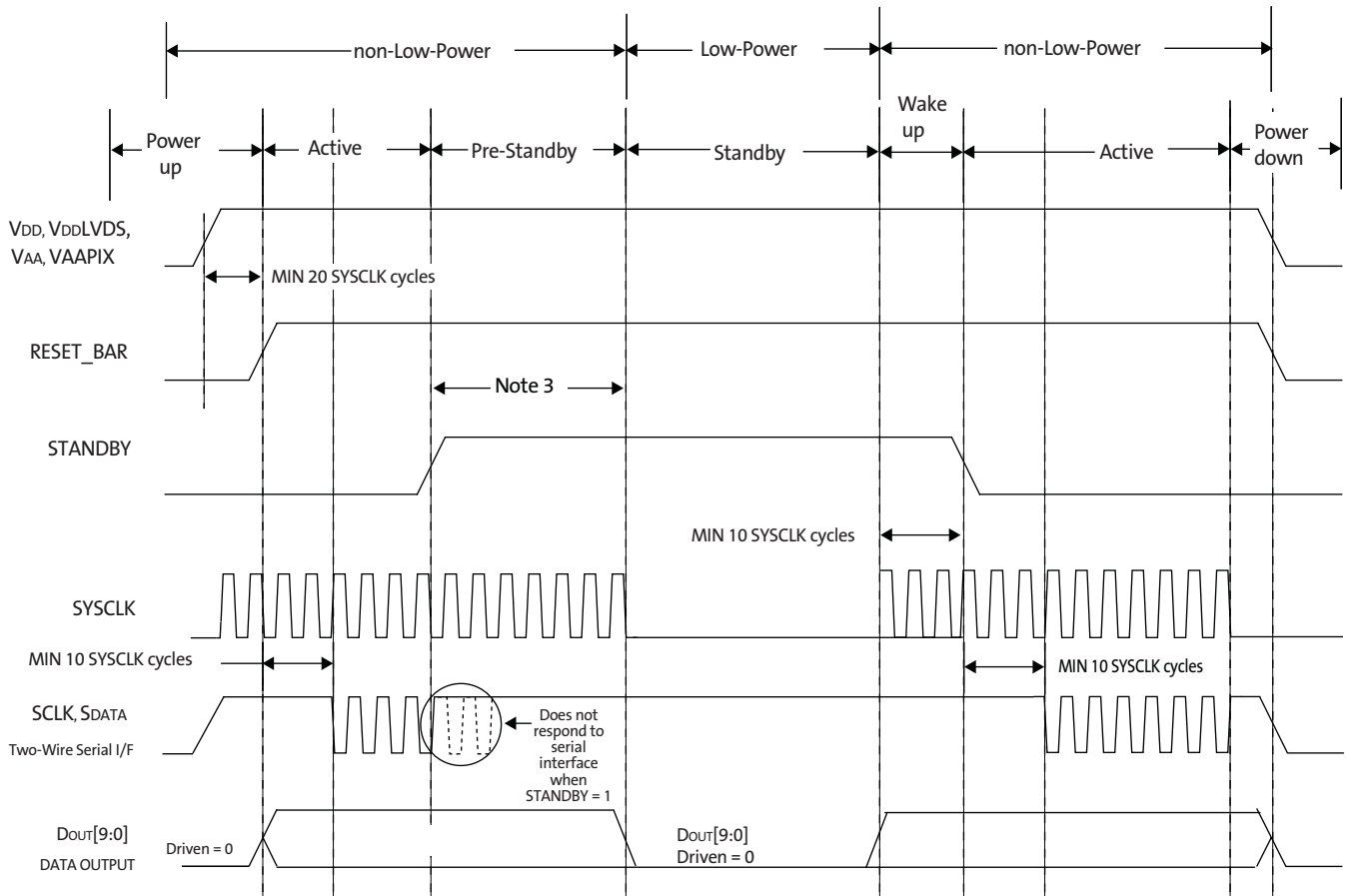
Note: All dimensions in millimeters.



## Appendix A – Power-On Reset and Standby Timing

There are no constraints concerning the order in which the various power supplies are applied; however, the MT9V024 requires reset to operate properly at power-up. Refer to Figure 48 for the power-up, reset, and standby sequences.

**Figure 48: Power-up, Reset, Clock, and Standby Sequence**



- Notes:
1. All output signals are defined during initial power-up with RESET\_BAR held LOW without SYSCLK being active. To properly reset the rest of the sensor, during initial power-up, assert RESET\_BAR (set to LOW state) for at least 750ns after all power supplies have stabilized and SYSCLK is active (being clocked). Driving RESET\_BAR to LOW state does not put the part in a low power state.
  2. Before using two-wire serial interface, wait for 10 SYSCLK rising edges after RESET\_BAR is de-asserted.
  3. Once the sensor detects that STANDBY has been asserted, it completes the current frame readout before entering standby mode. The user must supply enough SYSCLKs to allow a complete frame readout. See Table 4, "Frame Time," on page 14 for more information.
  4. In standby, all video data and synchronization output signals are driven to a low state.
  5. In standby, the two-wire serial interface is not active.



## Revision History

Rev. A .....	9/19/2008
• Initial release	

3080 North 1st Street, San Jose, CA 95134, prodmktg@aptina.com www.apina.com  
Aptina, Aptina Imaging, DigitalClarity, and the Aptina logo are the property of Micron Technology, Inc.  
All other trademarks are the property of their respective owners.

This data sheet contains minimum and maximum limits specified over the power supply and temperature range set forth herein. Although considered final, these specifications are subject to change, as further product development and data characterization sometimes occur.