

MT9P401



5-Megapixel
1/2.5-Inch
CMOS Image Sensor
Die or 48-Pin iLCC

Ultra-Fast, High-Quality HD Video

- 1 HD Video at Fast Frame Rates**
Speed is the key to capturing stunning 1080p HD video at 30 fps and 720p HD video at 60 fps.
- 2 Unparalleled Video Image Quality**
Vivid HD video quality along with clear and brilliant still images for consumer-class camcorders.
- 3 Small Footprint, Simple Design**
The 12-bit ADC for high-resolution image capture and HDTV video formats is a one-chip solution that enables a small footprint and easy design.
- 4 Fast Response Times and Short Focus Times**
15 fps image capture at full resolution provides specialized high-speed DSC performance that can't be matched by CCDs.
- 5 Low Power Consumption**
Low power advantages of CMOS technology extend the life of a DSC/DVC battery.

Applications

- Digital video cameras
- HD hybrid cameras
- Digital still cameras



How to Buy

Production and sample quantities of Aptina products may be ordered through qualified distributors. See our Web site for details. You may also request access to NDA data sheets and other technical documentation by visiting our Web site.

MT9P401

Features

- Ultra-fast frame rate for high-quality HD video
- Vivid HD video quality and clear and brilliant still images
- High-quality 2.2 μ m pixel
- Low-power, progressive scan CMOS image sensor
- 5-megapixel resolution (2592H x 1944V)
- High-definition video capture
- Viewfinder, bulb, and snapshot modes
- On-chip, 12-bit analog-to-digital converter (ADC)
- Excellent low-light sensitivity
- Programmable gain and exposure control
- Two-wire serial interface
- Global reset
- Binning for enhanced viewing experience
- Phase-locked loop (PLL) for versatile clock-in scheme

Specifications

Imaging Array

- Optical Format: 1/2.5-inch
- Active Array: 2592(H) x 1944(V)

Speed/Output

- Imaging Area: 5.70mm(H) x 4.28mm(V)
- Frame Rate: 15 fps at full resolution (5Mp)
30 fps at 1,080p
60 fps aaaaaat 720p

- Data Rate: 96 Mp/s
- Master Clock: 96 MHz
- Data Format: 12-bit progressive scan

Sensitivity

- Pixel Size: 2.2 μ m x 2.2 μ m
- Dynamic Range: 70dB
- Responsivity: 1.4 V/lux-sec (550nm)

Power

- Supply: Analog: 2.6–3.1V (2.8V nominal)
Digital: 1.7–1.9V (1.8V nominal)
I/O: 1.7–3.1V
- Consumption: 381mW at full resolution

Temperature Range

- Operating: –30°C to +70°C

Package: 48-pin iLCC or die

Block Diagram

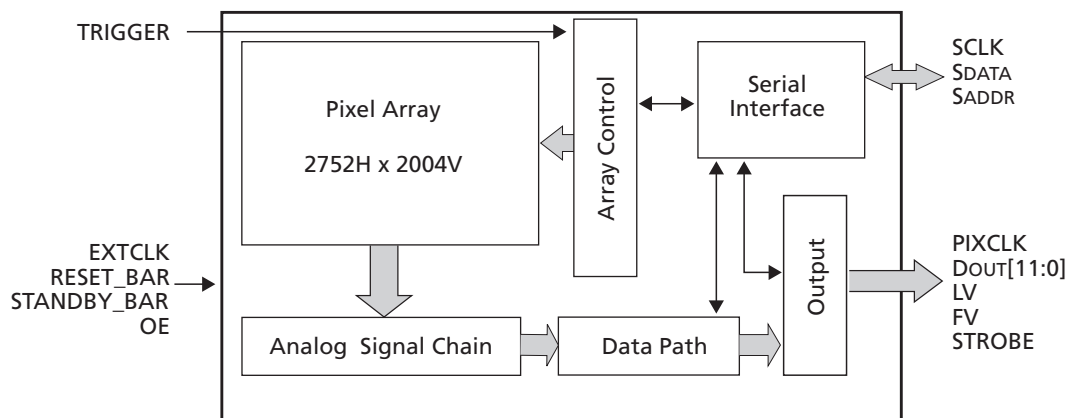

aptina.com

Products are warranted only to meet Aptina's production data sheet specifications. Aptina and the Aptina logo are trademarks of Aptina Imaging Corporation. All other trademarks are the property of their respective owners. © 2012 Aptina Imaging Corporation. All rights reserved. 05/8/12 EN.L

